

1992
LOUISIANA
TRAFFIC RECORDS
DATA REPORT

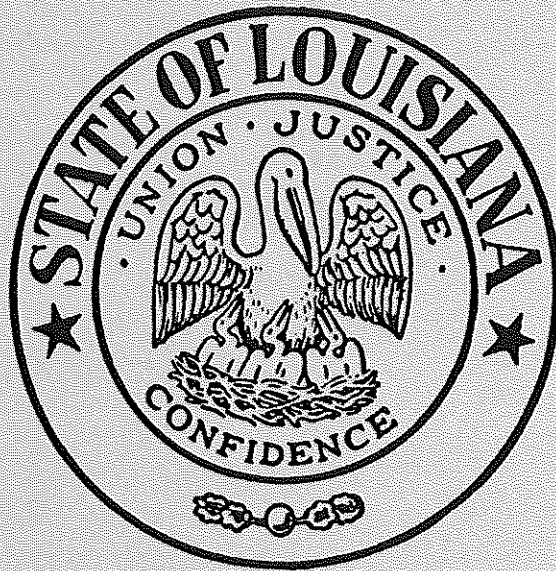

LOUISIANA HIGHWAY SAFETY COMMISSION
P.O. BOX 66336
BATON ROUGE, LOUISIANA
(504) 925-6991

This public document was published at a total cost of \$792.00. Five hundred (500) copies of this public document were published in this second printing at a cost of \$792.00. The total cost of all printings of this document, including reprints, is \$1,992.00. This document was published for the Louisiana Department of Public Safety and Corrections, Louisiana Highway Safety Commission, Post Office Box 66336, Baton Rouge, Louisiana 70896 by Moran Printing, Incorporated, 5425 Florida Boulevard, Baton Rouge, Louisiana 70806 to inform Louisiana citizens and public officials about the magnitude of the highway safety problem in the state. This material was printed in accordance with standards for printing by state agencies established pursuant to R.S. 43:31.

TABLE OF CONTENTS

	PAGE
DEFINITIONS.....	1
TRAFFIC CRASH FACTS.....	3
FATAL INJURIES BY CAUSE, U.S.1990.....	5
FATAL AND INJURY CRASHES/FATAL CRASHES.....	6
DEATH RATES/VEHICLE MILES TRAVELED.....	7
FATAL & INJURY CRASHES/FATAL CRASHES.....	8
FATALITIES/ALCOHOL FATALITIES.....	9
FATAL & INJURY CRASHES/FATAL CRASHES.....	10
INJURIES.....	11
ALCOHOL FATAL & INJURY CRASHES BY TROOP AREAS.....	12
CRASHES/URBAN AND RURAL.....	13
CRASHES/ALCOHOL/SPEED.....	14
CRASHES BY MONTH/DAY OF WEEK.....	15
WEATHER CONDITIONS/TYPE OF VEHICLE.....	17
ROAD SURFACE CONDITION/HIGHWAY TYPE.....	18
INTERSTATE ROADWAYS.....	19
SPEED INVOLVED CRASHES.....	21
DRIVERS HAD BEEN SPEEDING.....	23
HOLIDAY PERIODS.....	24
TRAIN CRASHES.....	25
MOTORCYCLE CRASHES.....	26
SEAT BELT SURVEY REGIONS.....	27
SEAT BELT/CHILD RESTRAINT USAGE.....	28
TYPE OF COLLISION.....	29
CONTRIBUTING FACTORS IN F&I CRASHES/CONDITION OF DRIVER...	30
1992 TRAFFIC CONVICTIONS.....	31
DWI CONVICTIONS.....	32
DWI ARRESTS AND CONVICTION.....	33
PARISH RANKING.....	37
POPULATION, LICENSED DRIVERS AND REGISTERED VEHICLES.....	41
LHSC FATAL AND INJURY ACCIDENT DATA.....	42
1992 YOUTH TRAFFIC CRASH DATA.....	53
DRINKING AND DRIVING PENALTIES.....	64
OCCUPANT PROTECTION ENFORCEMENT INFORMATION.....	65
1993 AAA STATE SAFETY LAWS.....	66

4
INTRODUCTION

The 1992 LOUISIANA TRAFFIC RECORDS DATA REPORT represents an important element of Louisiana's traffic safety program. The exact nature of this data is aimed at assisting the various professionals involved in traffic safety by presenting to them where they can best concentrate their safety efforts.

This report is a valuable resource for news media, legislators, medical personnel, researchers, law enforcement agencies, judicial personnel, insurance companies, businesses, students and persons involved in traffic safety activities. Through careful analysis of this data, relevant information can be learned about crashes, vehicles, drivers and roadways. Solutions can be found -- laws can be introduced, safety programs can be implemented, highway improvements can be made and enforcement can be increased.

When analyzing a particular table or chart it is important to note whether referencing the number of crashes, the number of people or the number of vehicles.

Requests for further information or additional copies of this report should be addressed to:

Department of Public Safety & Corrections
Louisiana Highway Safety Commission
Post Office Box 66336
Baton Rouge, LA 70896
Phone: (504) 925-6991

* Thus the ~~the~~ tables produced in this report may differ from the true values, because of missing information or recording errors. ~~All effort has been made to minimize these errors.~~
The ~~number of~~ missing information ~~is~~ is mentioned in the tables.

DEFINITIONS

The following special terms are used throughout the traffic safety community and some may be found throughout this report.

ALCOHOL INVOLVED CRASH (AIC) - Any CRASH in which a DRIVER or PEDESTRIAN had been drinking as indicated by the crash report.

COLLISION TYPE - The category which best describes the general type of collision which was the first event.

CRASH (TRAFFIC) - An unintended event that causes a death, injury or damage and involves a MOTOR VEHICLE on a TRAFFICWAY. (This book includes only traffic crashes which have resulted in a DEATH or INJURY to one or more persons. CRASHES which have caused only vehicle or property damage are not included.)

DEATHS (FATALITIES) - Those persons who have died within 30 days of a CRASH as a result of INJURIES sustained in that CRASH.

DRIVER - A person who is in actual physical control of a VEHICLE or who was in control until control was lost. (A PEDALCYCLIST who is in control is considered a DRIVER.)

DRIVER CONDITION - The category which best describes the condition of a DRIVER at the time of the CRASH.

FATAL ACCIDENTS - Those CRASHES in which there was one or more DEATHS.

FATAL AND INJURY (F&I) CRASH - The CRASHES in which there was an INJURY or a DEATH.

INJURY - Bodily harm to a person as a result of a CRASH. INJURIES do not include DEATHS.

INTERSECTION CRASHES - Those crashes which occur at or within 100 feet of an intersection.

KILLED - A DEATH as a result of a CRASH.

LIGHT TRUCKS - MOTOR VEHICLES such as pickups, vans, blazers, and panel trucks.

LICENSED DRIVER - A person who is licensed by a state to operate a MOTOR VEHICLE on public roadways.

LOCATION TYPES - Where the CRASH occurred (business, residential, etc.)

DEFINITIONS (CONTINUED)

MOTOR VEHICLES - Any motorized (mechanically or electrically powered) VEHICLE not operated on rails.

OCCUPANT - A person who is in or on a VEHICLE.

OTHER OBJECT - An object in the roadway which is not part of the roadway (such as rocks, fallen trees, debris).

PASSENGER - Any OCCUPANT of a VEHICLE other than its DRIVER.

PEDALCYCLE - A nonmotorized VEHICLE propelled by pedalling such as a bicycle, tricycle, unicycle, or pedalcar. (The PEDALCYCLE is counted as a VEHICLE and the OCCUPANTS are counted as DRIVERS and PASSENGERS.)

PEDESTRIAN - A person who is INJURED or killed in a CRASH and who was not in or on a VEHICLE.

PRIMARY CONTRIBUTING FACTOR - The main cause of a CRASH.

RANK - All areas that are unincorporated and incorporated areas with less than 2,500 population - except for Jefferson Parish which is considered all URBAN.

TRAFFICWAY - A land way open to the public as a matter of right or custom for moving persons or property from one place to another. This does not include land ways which are under construction or closed and which have been marked by signing or barriers.

TRUCK COMBINATION - A motor vehicle consisting of a TRUCK TRACTOR which has a trailer or semitrailer attached.

TRUCK TRACTOR - A motor vehicle consisting primarily of a single motorized device designed for drawing trailers or semitrailers, but not for carrying other property on or in the device. When connected to a trailer or semitrailer, such a device is considered a TRUCK COMBINATION.

URBAN - Any incorporated area with more than 2,500 population and all of Jefferson Parish.

VEHICLE - A device for carrying or transporting persons or things, i.e., cars, trucks, farm equipment, buses, motorcycles, pedalcycles, trains, and recreational vehicles.

VIOLATIONS - The category which best describes the DRIVER'S infringement of MOTOR VEHICLE traffic laws.

TRAFFIC CRASH FACTS

- Nationally motor vehicle crashes are the leading cause of death among Americans 1-34 years old.
- 31% of all fatal injuries in 1990, for all age groups were caused by motor vehicle crashes.
- More crashes occur in the urban areas but more fatalities occur in the rural areas.
- National fatality rate has fallen from 2.6 in 1983 to 1.8 (lowest in history) in 1992. Louisiana during same period fell from 2.8 in 1983 to 2.6 in 1992 based on fatality rate per 100 million vehicle miles traveled. Last published ranking based on fatality rates in 1991 showed Louisiana to be number 10.
- Alcohol related fatalities during the same period (1983-92) fell nationally from 56% to 45%. Louisiana alcohol fatalities during this same period have fluctuated between 38% and 43%. The last five years they have remained constant around 42%. (The National Highway Traffic Safety Administration's Fatal Accident Reporting System (FARS) shows Louisiana to be at 56% in 1992. The difference is due to the methodology/statistical model used by FARS in computing alcohol related fatalities).
- National statistics showed 39,235 fatalities in 1992; lowest number of deaths since 1961 which was 38,061. In 1961, Louisiana had 779 fatalities and 892 in 1992. Louisiana experienced an all time high of 1,302 fatalities in 1968. Nationally fatalities peaked in 1969 at 56,000. For the last five years with the exception of 1990 (979 fatalities) Louisiana's fatalities range somewhere between 850 and 900.
- National safety belt use has risen from 59% in 1991 to 66% in 1993. Louisiana's has risen from 42% to 48% during the same time period. However, we are still below the national average.
- Even at BACs as low as 0.02 percent, alcohol affects driving ability and crash likelihood. The probability of a crash begins to increase significantly at 0.05 percent BAC and climbs rapidly after about 0.08 percent. For drivers with BACs above 0.15 percent on weekend nights, the likelihood of being killed in a single-vehicle crash is more than 380 times higher than it is for nondrinking drivers.
- NHTSA estimates that 941 lives were saved in 1991 by age 21 drinking laws. Since 1982, it is estimated that almost 8,743 lives have been saved in the affected ages by these laws. However, young people under age 21 are still greatly over-represented in alcohol-related crashes and fatalities.

TRAFFIC CRASH FACTS (CONTINUED)

- Recent research indicates that the relative fatality risk for drivers in single vehicle crashes with BACs between 0.05 and 0.09 is over 11 times greater than for drivers with a zero BAC.
- A BAC level of 0.08 means about four drinks within one hour on an empty stomach for an average male weighing 160 pounds.
- Any impairment, regardless of BAC can result in an arrest.
- In 1992, there was one person killed every 9 hours and 49 minutes in a traffic crash in Louisiana.
- In 1992, there were 371 people killed in alcohol-related crashes in Louisiana. Every 23 hours and 37 minutes someone dies in an alcohol-related crash in Louisiana.
- In 1992, there were 76,676 people injured in traffic crashes in Louisiana. Every 6 minutes and 51 seconds someone is injured in a traffic crash in Louisiana.
- In 1992, there were 8,915 people injured in alcohol-related crashes in Louisiana. Every 59 minutes someone is injured in an alcohol-related crash in Louisiana.
- Lap and shoulder belts, when used, are the single most effective means for occupants to reduce the risk of death and serious injury in a highway crash.
- In 1992, if every front seat occupant had buckled up, more than 14,000 deaths and several hundred thousand serious injuries nationally would have been prevented by seat belt use.
- The fatalities and injuries that are prevented by safety belt use laws result in significant economic savings to society. In 1990, at a usage rate of about 50%, the societal savings were estimated to be \$3.5 billion. One study pointed out that for persons hospitalized as a result of a traffic crash, their first year medical costs alone totaled nearly \$6.5 billion. Nearly one-third of these costs were borne by government.
- In 1992, it is estimated that the economic costs of traffic crashes in Louisiana totaled \$2,077,176,095.
- The cost to society of injured crash survivors is 2.2 times more than for fatalities.
- The total economic cost of crashes nationally is \$137.5 billion, with fatalities accounting for \$31.3 billion and injuries \$68.9 billion of that figure (PDO/uninjured accounts for the remainder).

FATAL INJURIES BY CAUSE, U.S., 1990 ALL AGE GROUPS

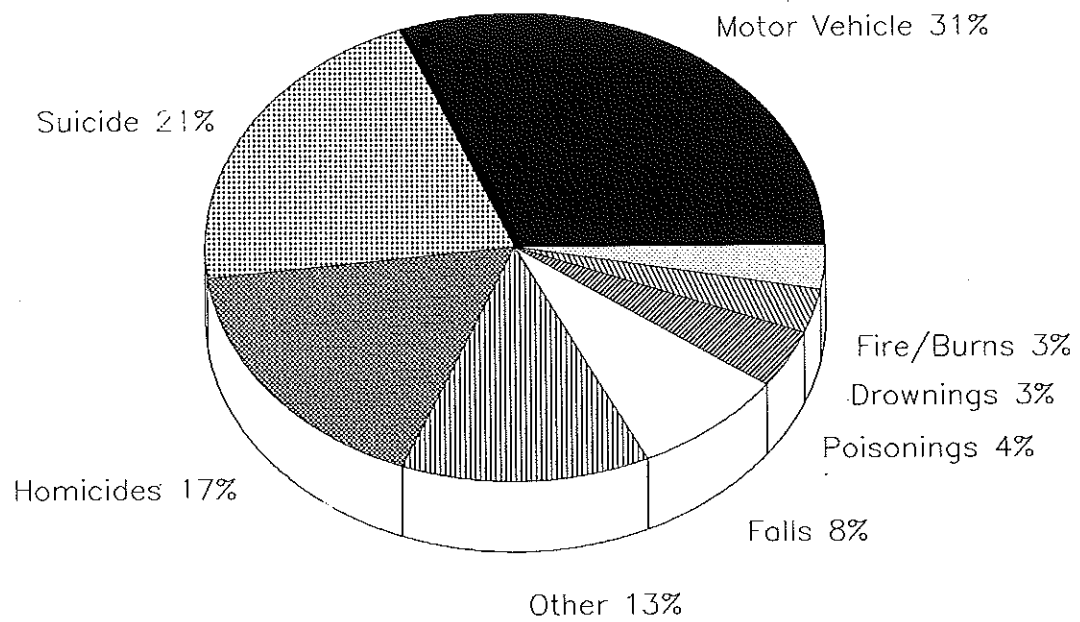

FATAL AND INJURY CRASHES

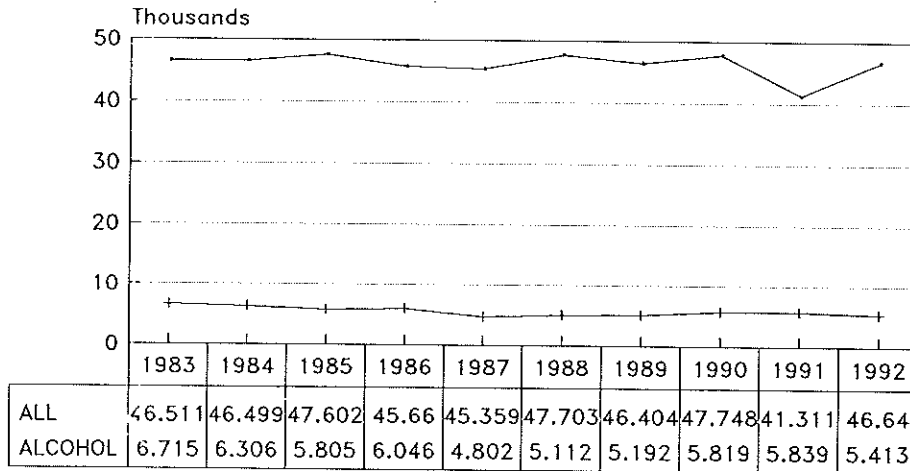

— ALL + ALCOHOL

F&I

FATAL CRASHES

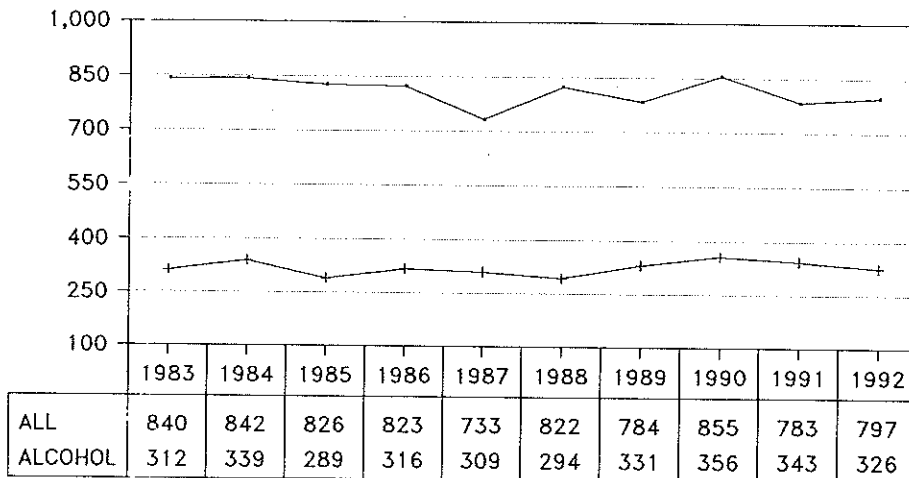

— ALL + ALCOHOL

FATAL

DEATH RATES 10 Year Rates- LA/US

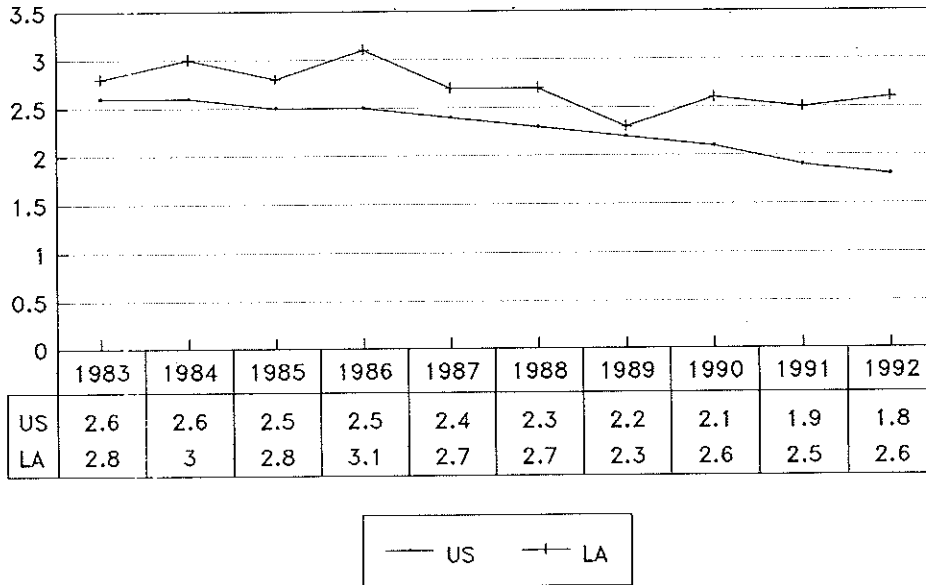

RATE95

VEHICLE MILES TRAVELED 10 Year Trend

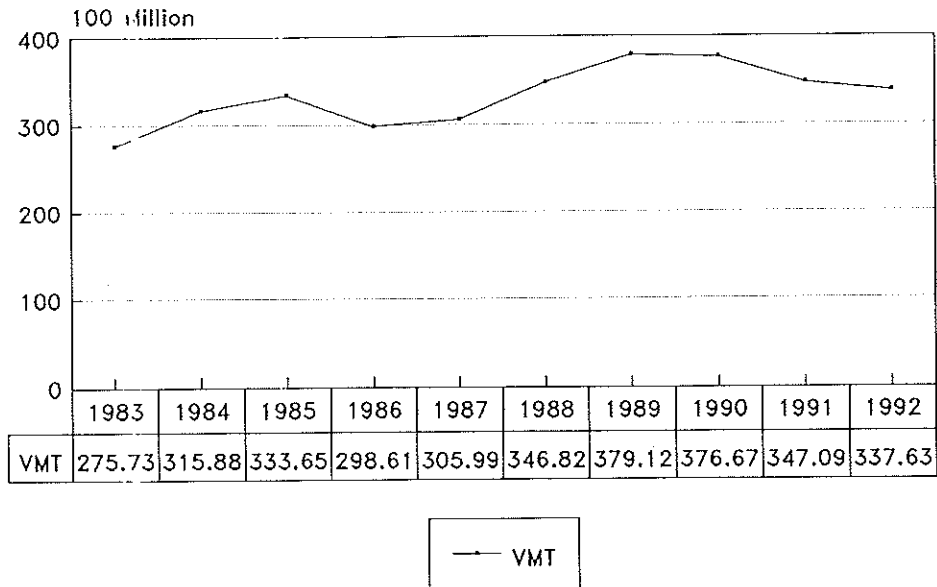

VMT

FATALITIES

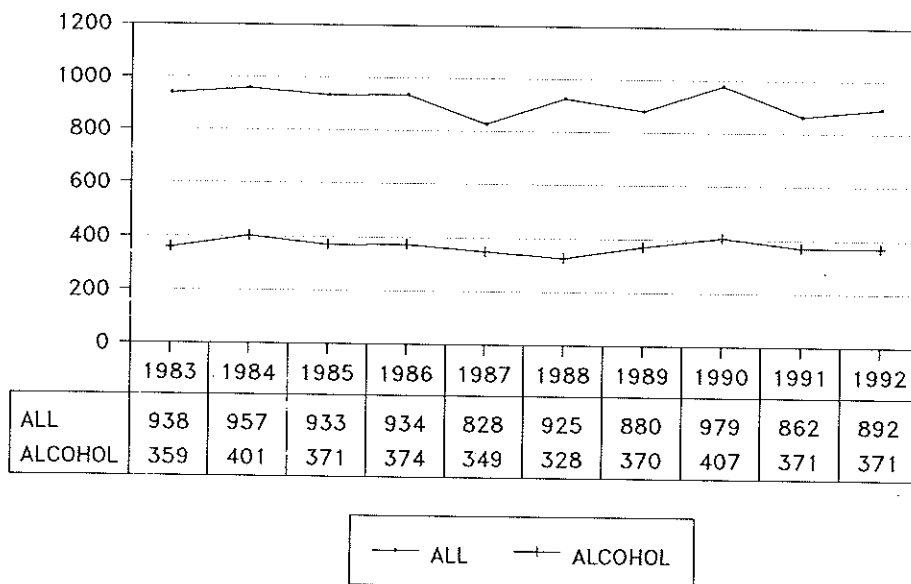

DEAT91

ALCOHOL FATALITIES PERCENT LA/US

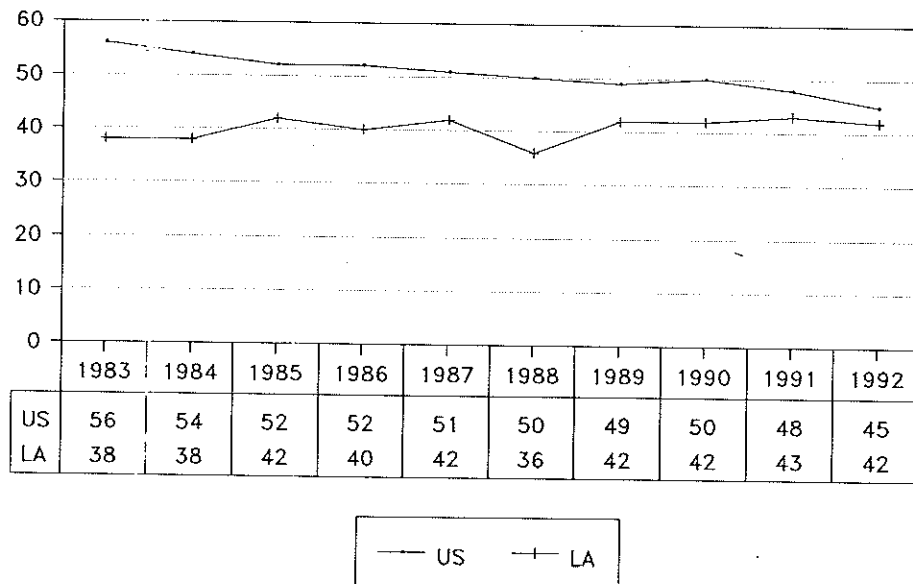

DEAT91B

FATAL & INJURY CRASHES ALL DRIVERS BY AGE

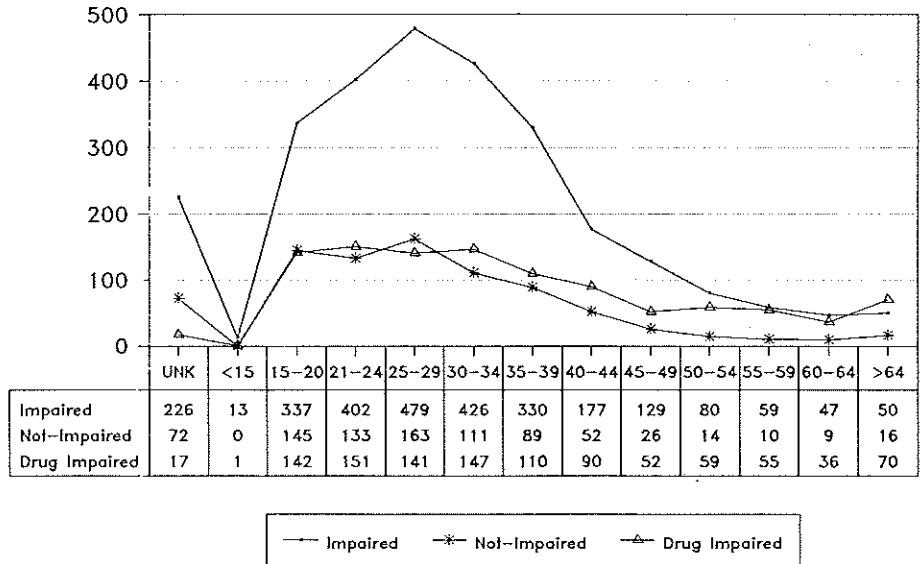

Impaired 2757; Not Imp 840; Drugged 1071
DRIVER1

FATAL CRASHES ALL DRIVERS BY AGE

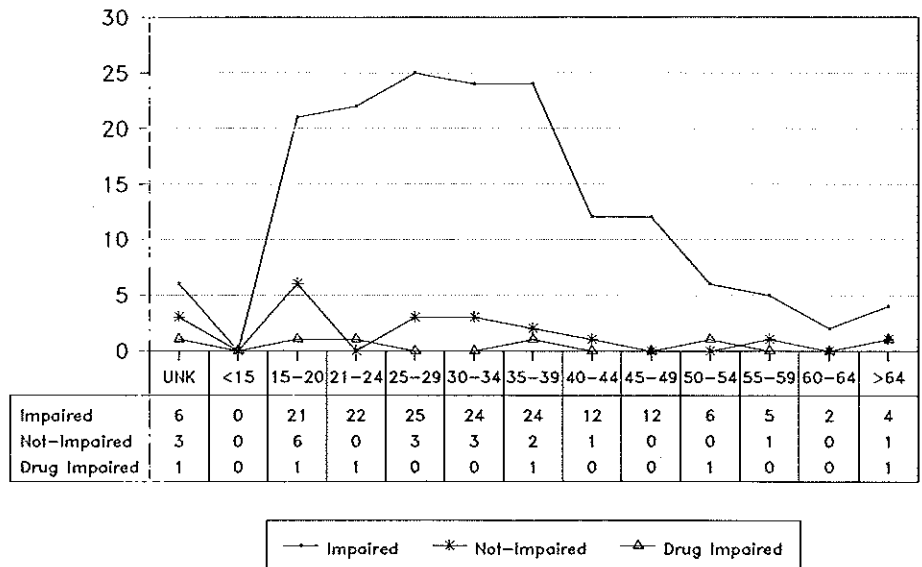

Impaired 163; Not Imp 20; Drugged 6
DRIVER1A

FATAL & INJURY CRASHES DRIVERS 15-24 BY AGE

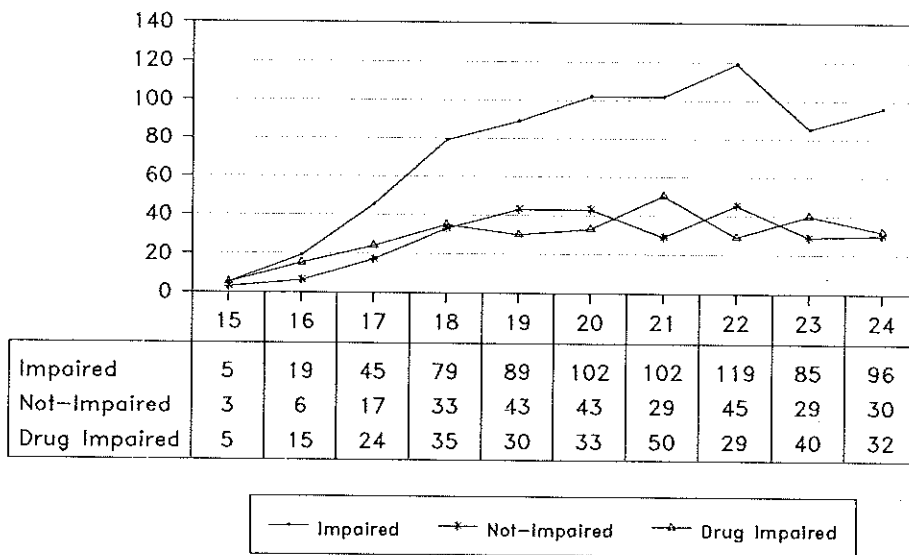

Impaired 741; Not Imp 278; Drugged 293
DRIVER3

FATAL CRASHES DRIVERS 15-24 BY AGE

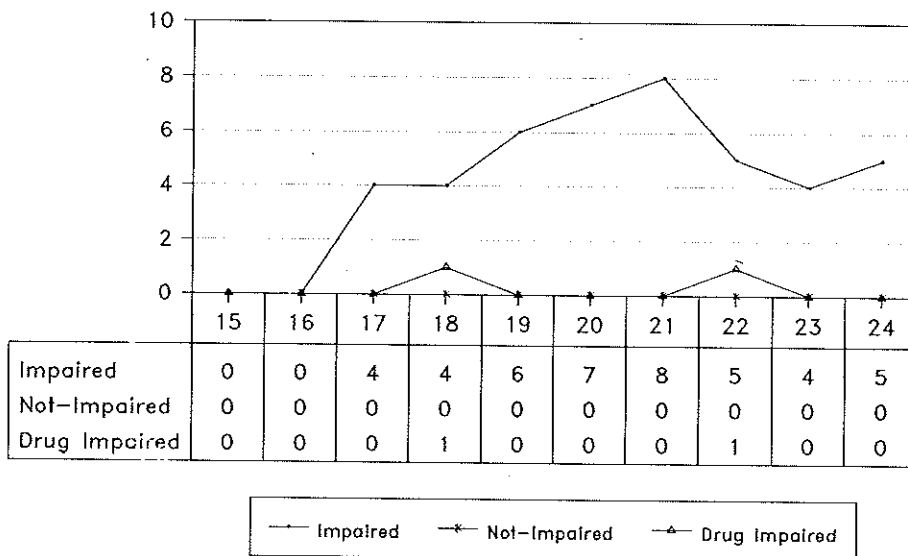

Impaired 43; Not Imp ???; Drugged 2
DRIVER3A

INJURIES

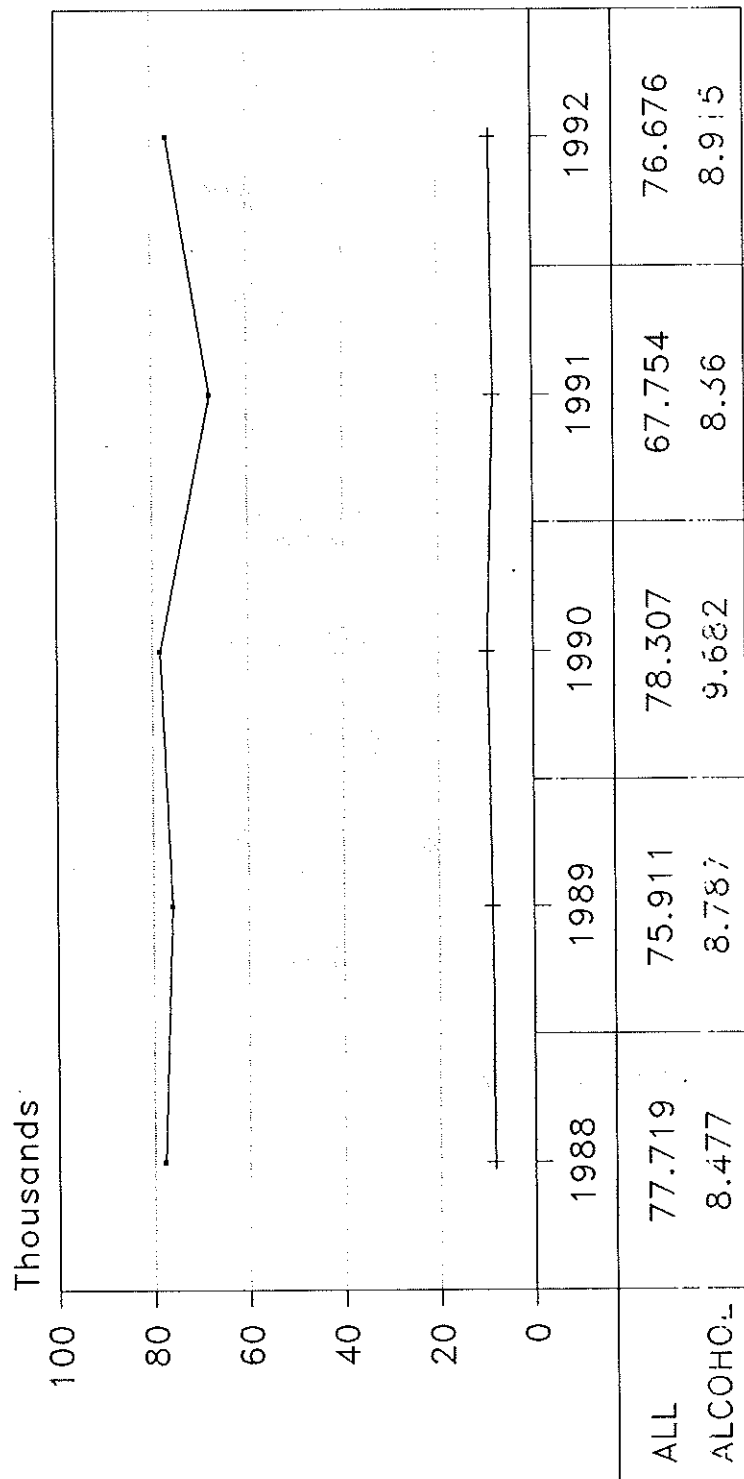

—■— ALL -x- ALCOHOL

INJURIES

Alcohol Fatal and Injury Crashes by State Police Troop Areas

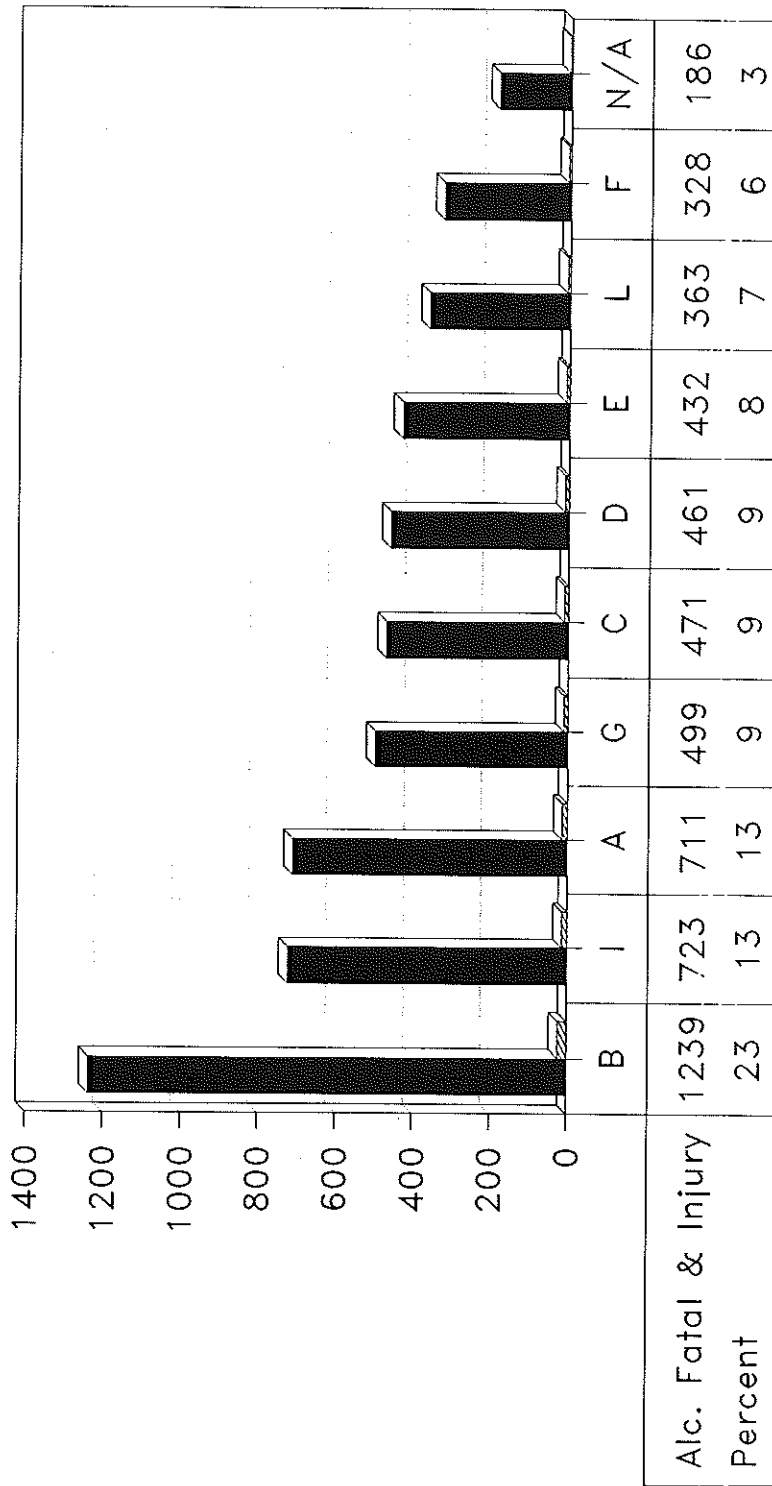

Alc. Fatal & Injury
 Percent

Source: LHSC HS1380 03/12/94

FATAL & INJURY CRASHES Urban and Rural

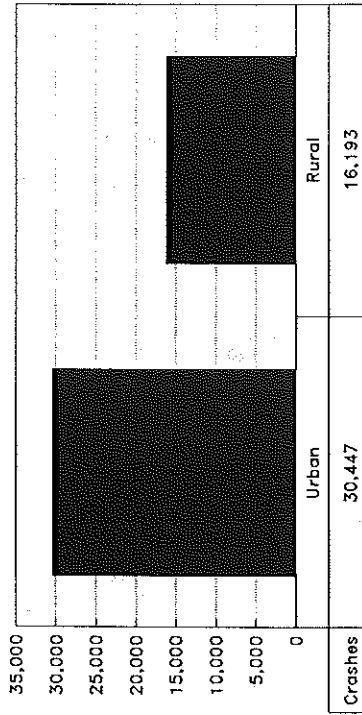

CRASHESM

Crashes

FATAL CRASHES Urban and Rural

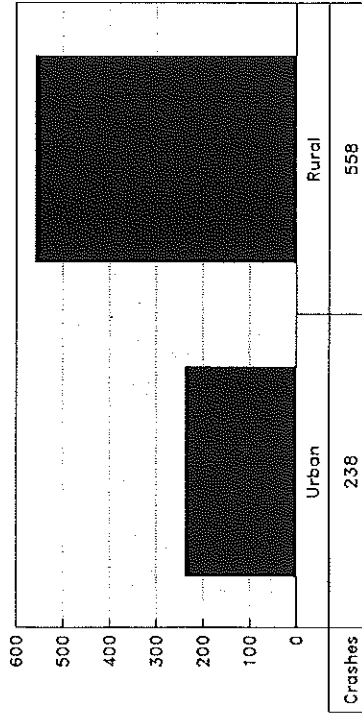

CRASHES0

Crashes

ALCOHOL F&I CRASHES Urban and Rural

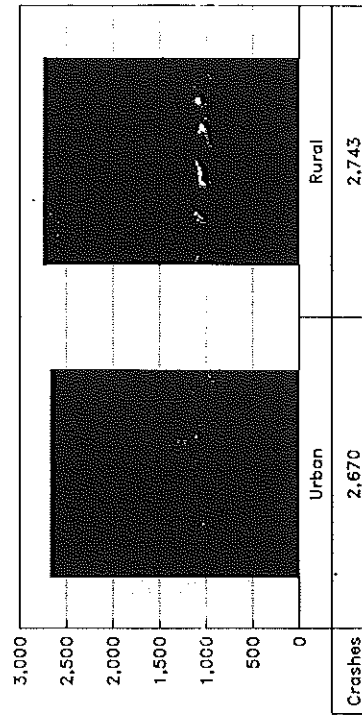

CRASHESN

Crashes

ALCOHOL FATAL CRASHES Urban and Rural

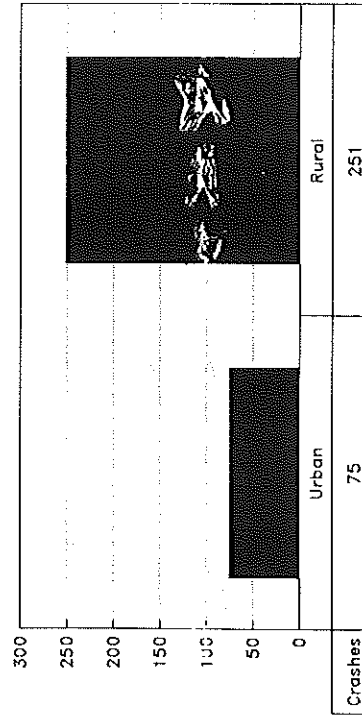

CRASHESR

Crashes

FATAL AND INJURY ALCOHOL AND SPEED

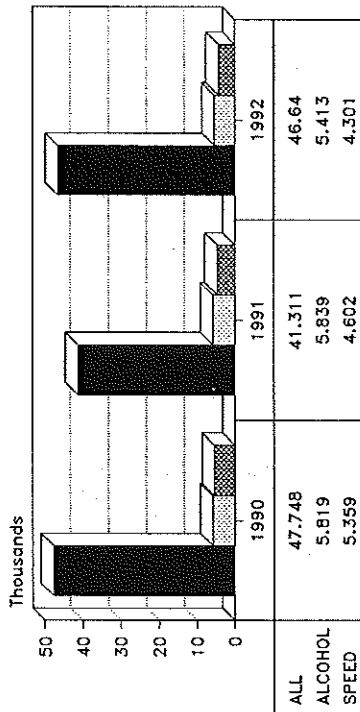

CRASHESA

FATAL CRASHES ALCOHOL AND SPEED

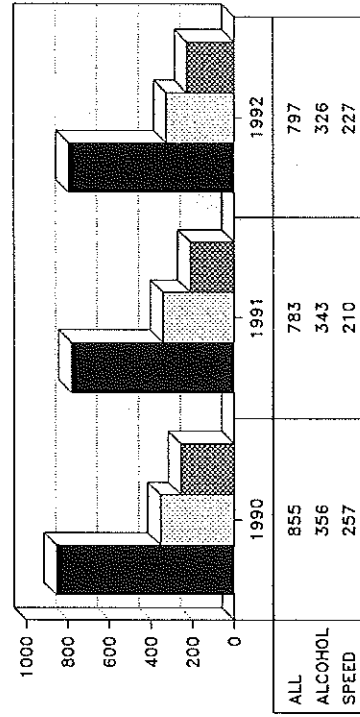

CRASHESC

PERCENT ALCOHOL/SPEED

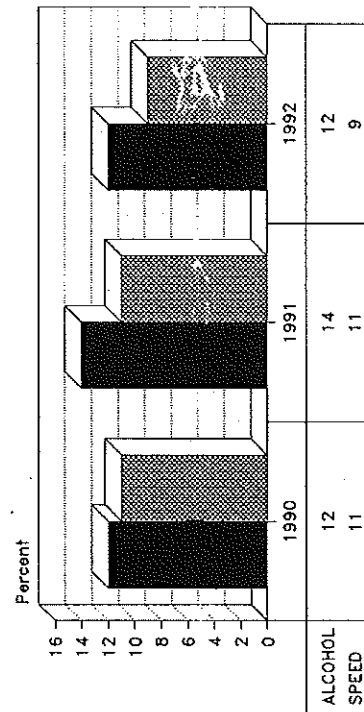

CRASHESB

PERCENT ALCOHOL/SPEED

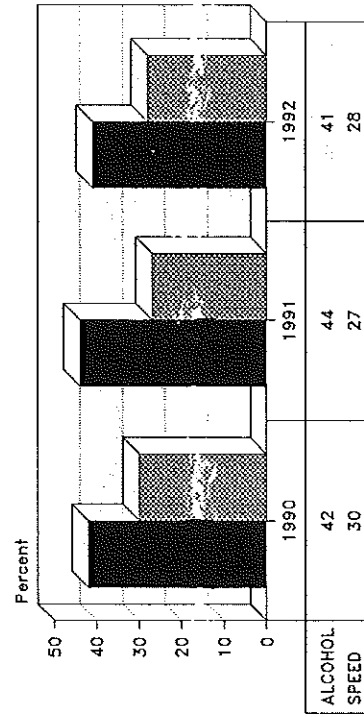

CRASHESD

CRASHES BY MONTH 1992

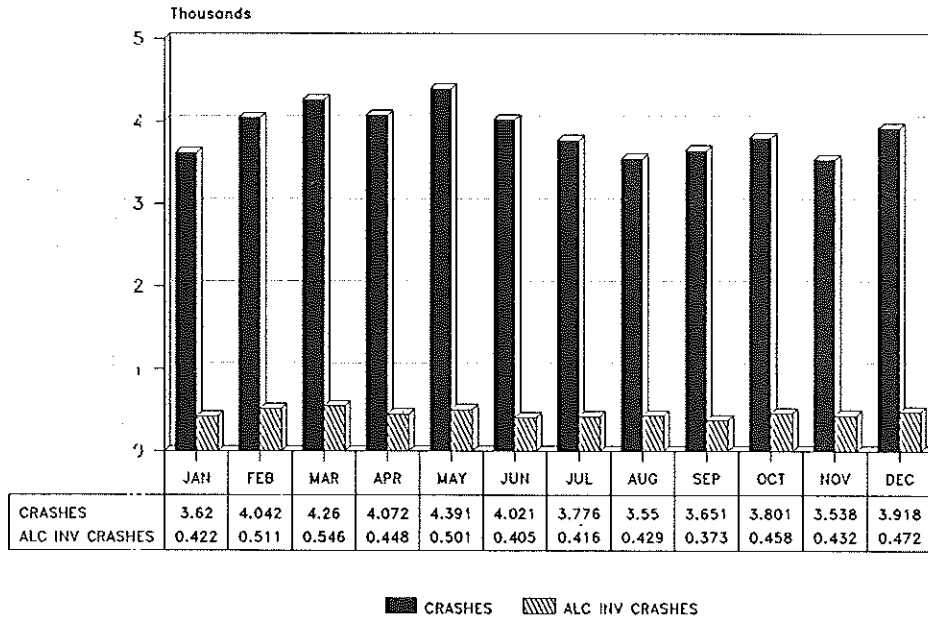

LHSC FATAL AND INJURY DATA

CRASHES BY DAY OF WEEK 1992

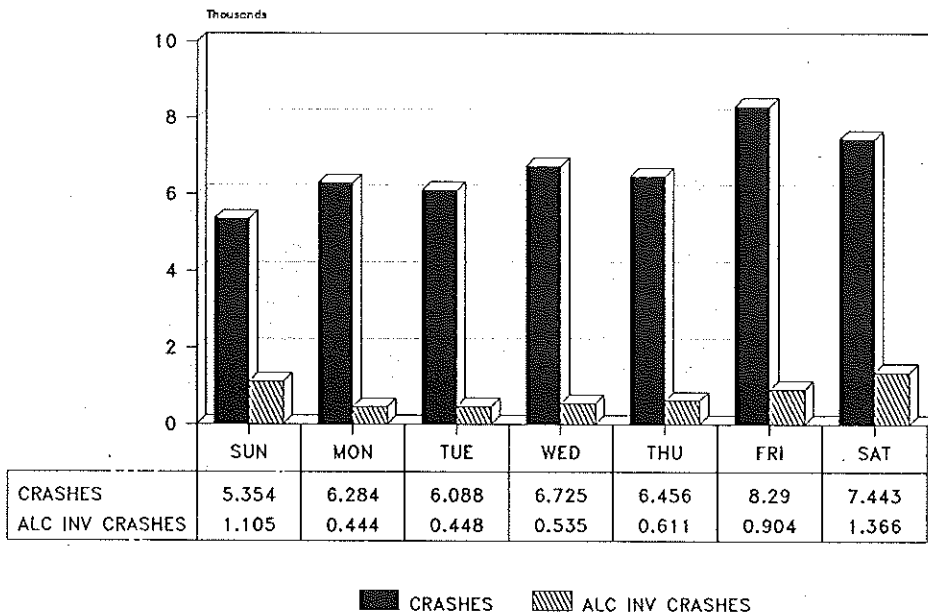

LHSC FATAL AND INJURY DATA

FATAL CRASHES BY MONTH 1992

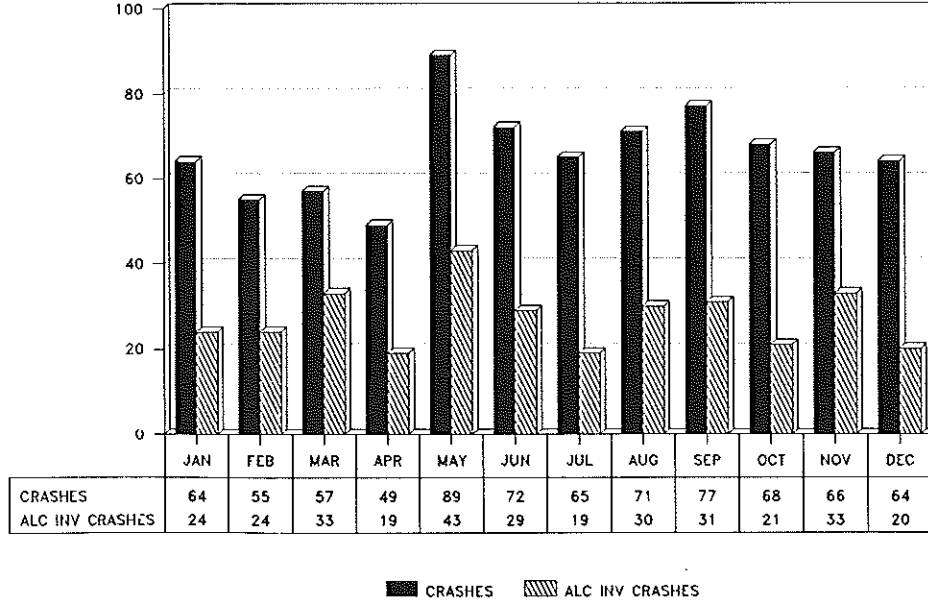

SOURCE: '92 HSI380 3/12/94

FATAL CRASHES BY DAY OF WEEK 1992

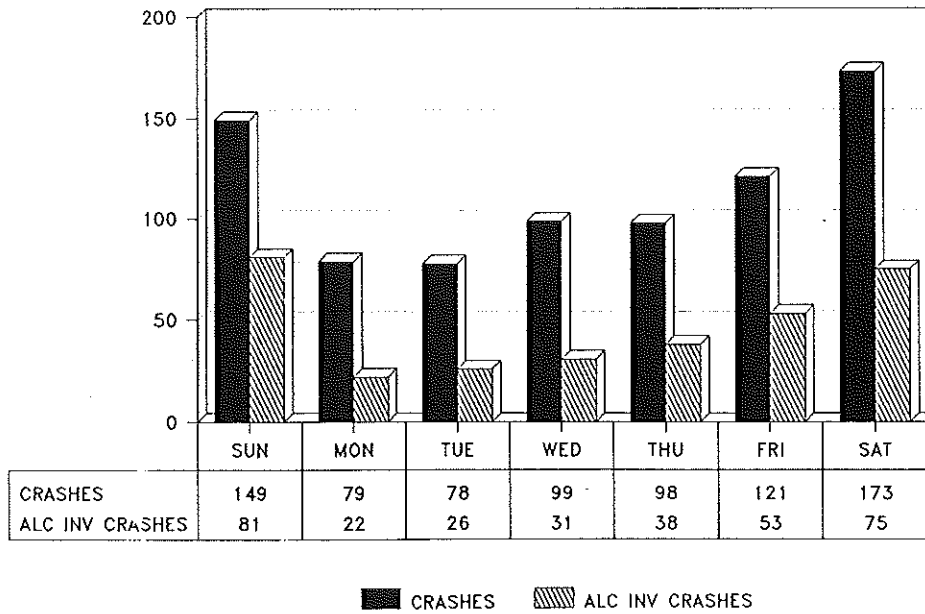

LHSC FATAL AND INJURY DATA

WEATHER CONDITIONS 1992

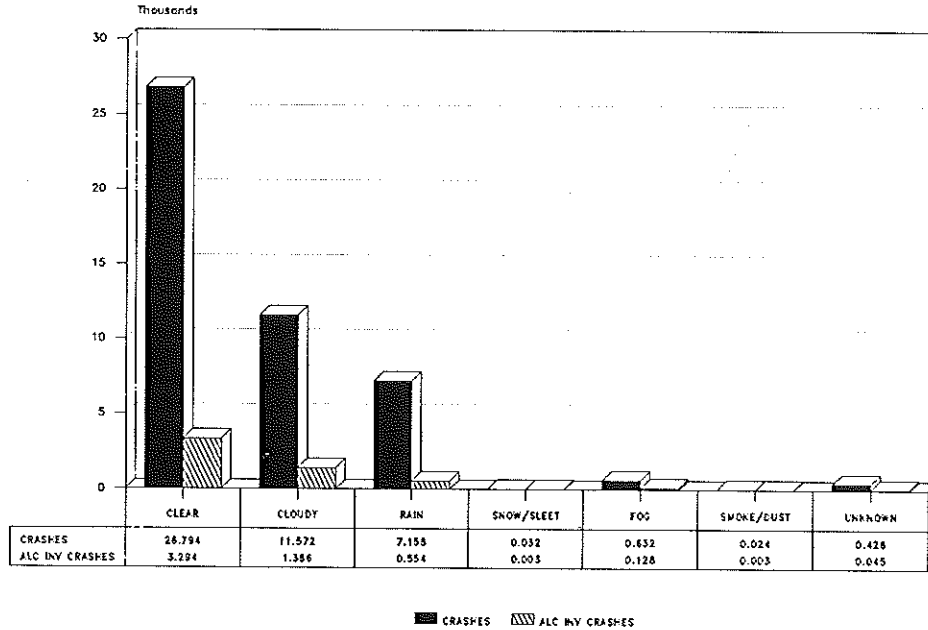

LHSC FATAL AND INJURY DATA

TYPE OF VEHICLE 1992

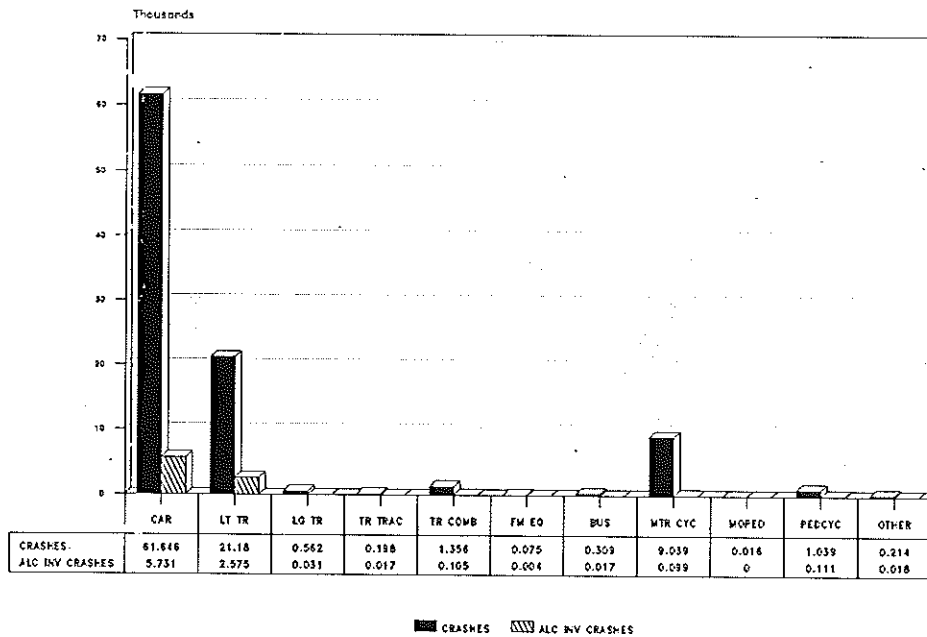

LHSC FATAL AND INJURY DATA

ROAD SURFACE CONDITION 1992

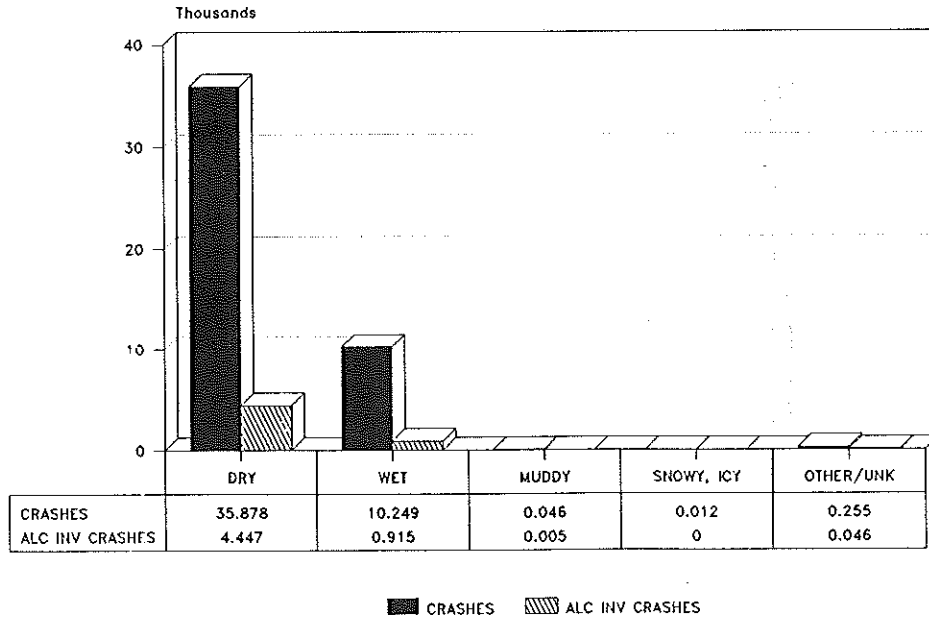

LHSC FATAL AND INJURY DATA

HIGHWAY TYPE 1992

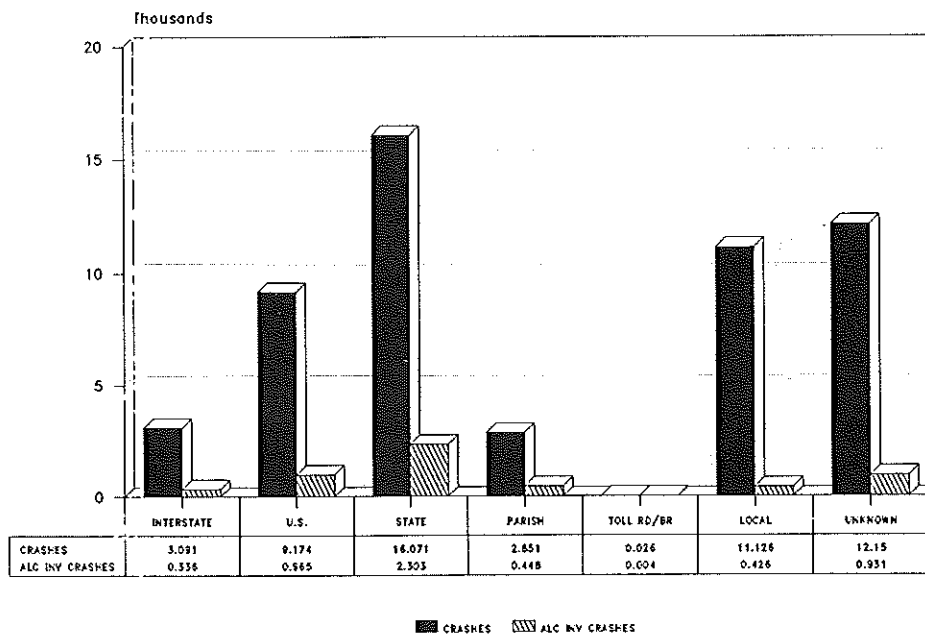

LHSC FATAL AND INJURY DATA

INTERSTATE ROADWAYS

INTERSTATE ROADWAY – ALL AREAS

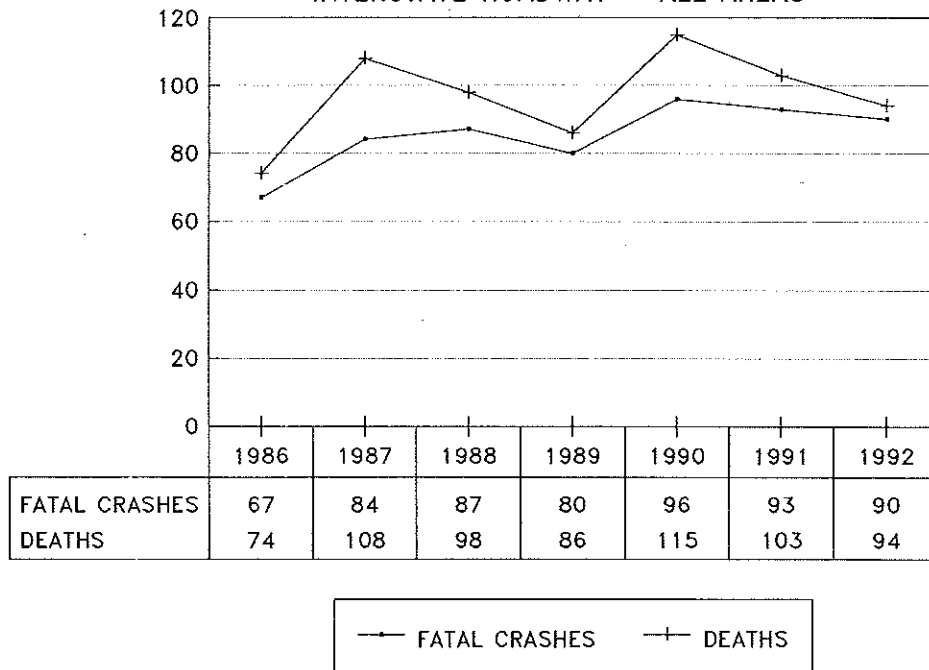

INTERSTATE ROADWAY – ONLY AREAS CHANGED TO 65

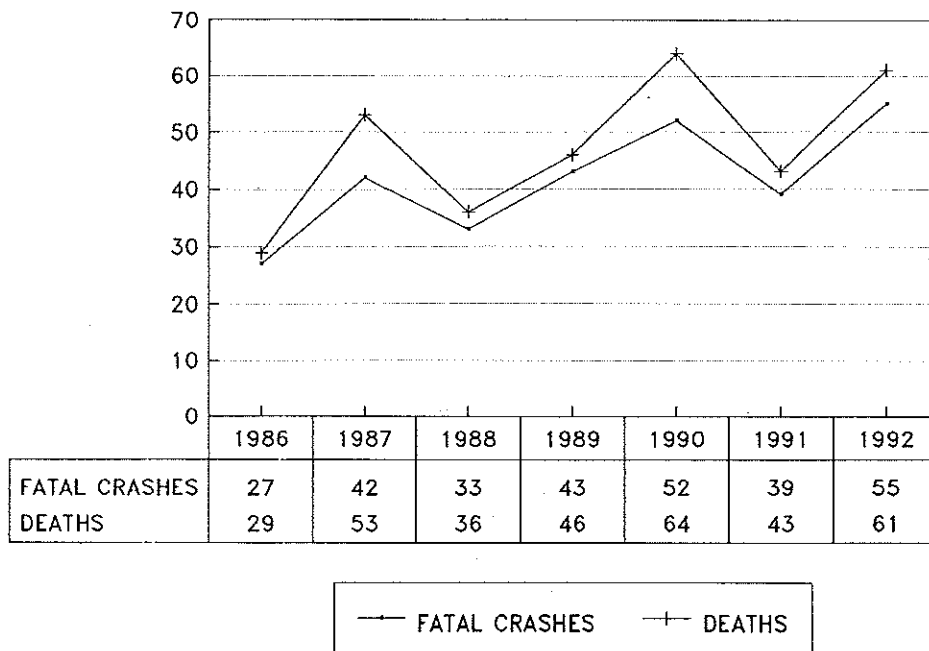

INTERSTATE ROADWAYS

INTERSTATE ROADWAY - ALL AREAS

	<u>FATAL ACCIDENTS</u>						<u>DEATHS</u>					
	1987	1988	1989	1990	1991	1992	1987	1988	1989	1990	1991	1992
I-10	50	47	45	47	58	50	66	53	46	53	64	50
I-12	4	7	11	13	6	7	5	9	14	16	6	9
I-20	12	11	10	17	14	13	17	11	11	26	15	15
I-49	3	4	4	5	4	11	3	4	4	5	4	11
I-55	9	7	4	7	5	4	10	9	5	7	7	4
I-59	0	4	3	2	0	2	0	4	3	2	0	2
I-110	1	3	0	1	1	1	1	3	0	1	1	1
I-210	0	2	1	0	3	0	0	3	1	0	3	0
I-220	0	0	1	0	1	0	0	0	1	0	1	0
I-310	1	0	0	0	0	0	2	0	0	0	0	0
I-610	4	2	1	4	1	2	4	2	1	5	2	2
	<u>84</u>	<u>87</u>	<u>80</u>	<u>96</u>	<u>93</u>	<u>90</u>	<u>108</u>	<u>98</u>	<u>86</u>	<u>115</u>	<u>103</u>	<u>94</u>

INTERSTATE ROADWAY - ONLY

AREAS CHANGED TO 65

	<u>FATAL ACCIDENTS</u>						<u>DEATHS</u>					
	1987	1988	1989	1990	1991	1992	1987	1988	1989	1990	1991	1992
I-10	23	18	21	18	18	28	28	18	21	22	19	28
I-12	4	3	6	10	5	7	5	4	8	12	5	9
I-20	5	5	6	12	10	8	9	5	7	18	11	11
I-49	1	1	4	3	2	6	1	1	4	3	2	7
I-55	9	5	3	7	4	4	10	7	3	7	6	4
I-59	0	1	3	2	0	2	0	1	3	2	0	2
	<u>42</u>	<u>33</u>	<u>43</u>	<u>52</u>	<u>39</u>	<u>55</u>	<u>53</u>	<u>36</u>	<u>46</u>	<u>64</u>	<u>43</u>	<u>61</u>

The SPEED LIMIT was changed to 65 MPH only for the RURAL areas of the INTERSTATE system starting in April, 1987.

URBAN AREAS ONLY SPEED INVOLVED CRASHES

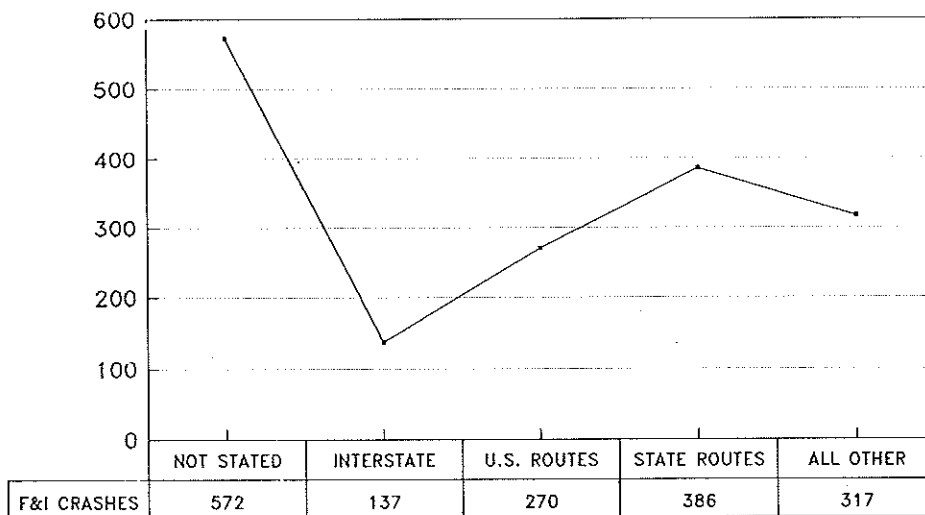

—■— F&I CRASHES

Crashes 1,682
SPEEDCC

DRIVERS BY AGE SPEED INVOLVED CRASHES

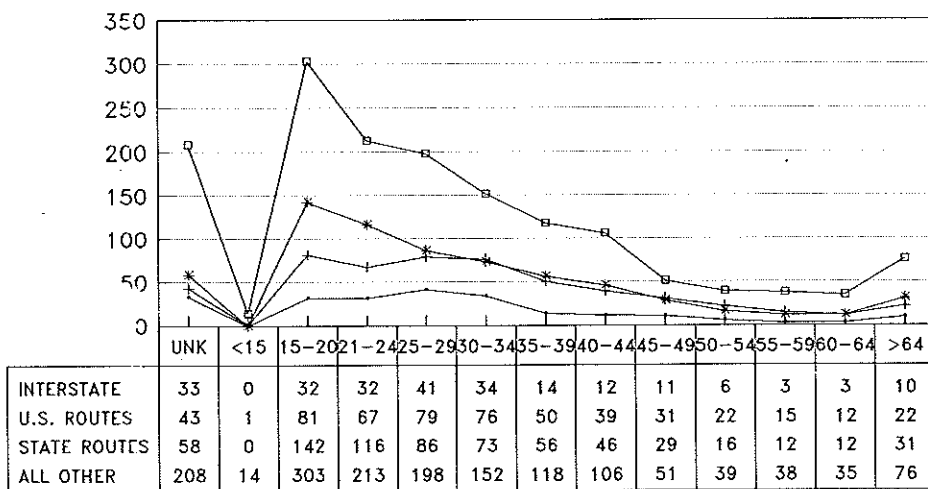

— INTERSTATE —+— U.S. ROUTES
 —*— STATE ROUTES —□— ALL OTHER

Crashes 1,682/Drivers 2,997
SPEEDC

RURAL AREAS ONLY SPEED INVOLVED CRASHES

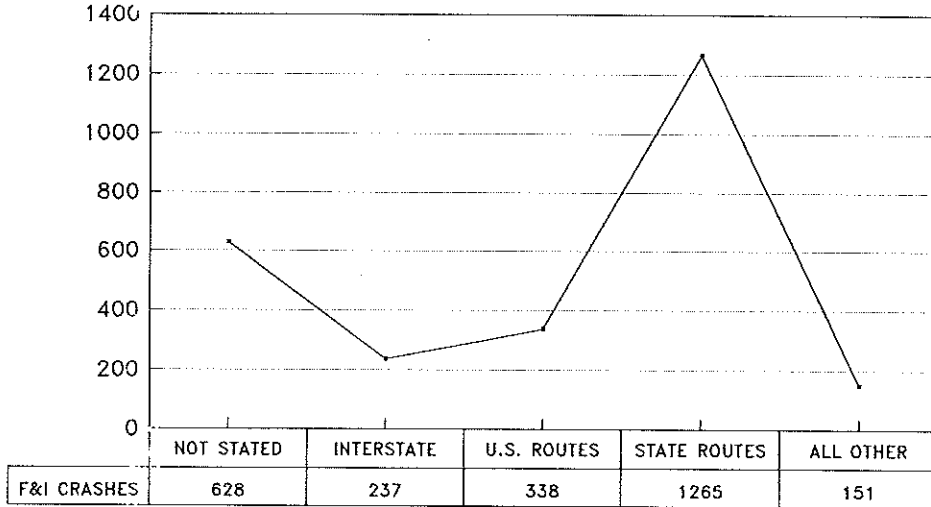

◆ F&I CRASHES

Crashes 2,619
SPEEDBB

DRIVERS BY AGE SPEED INVOLVED CRASHES

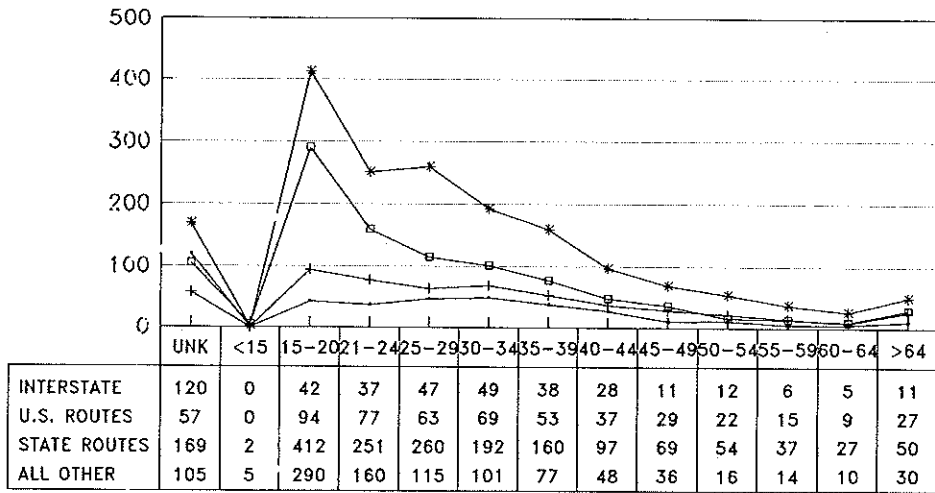

— INTERSTATE + U.S. ROUTES
 * STATE ROUTES □ ALL OTHER

Crashes 2,619/d. ivers 3,745
SPEEDB

DRIVERS HAD BEEN SPEEDING

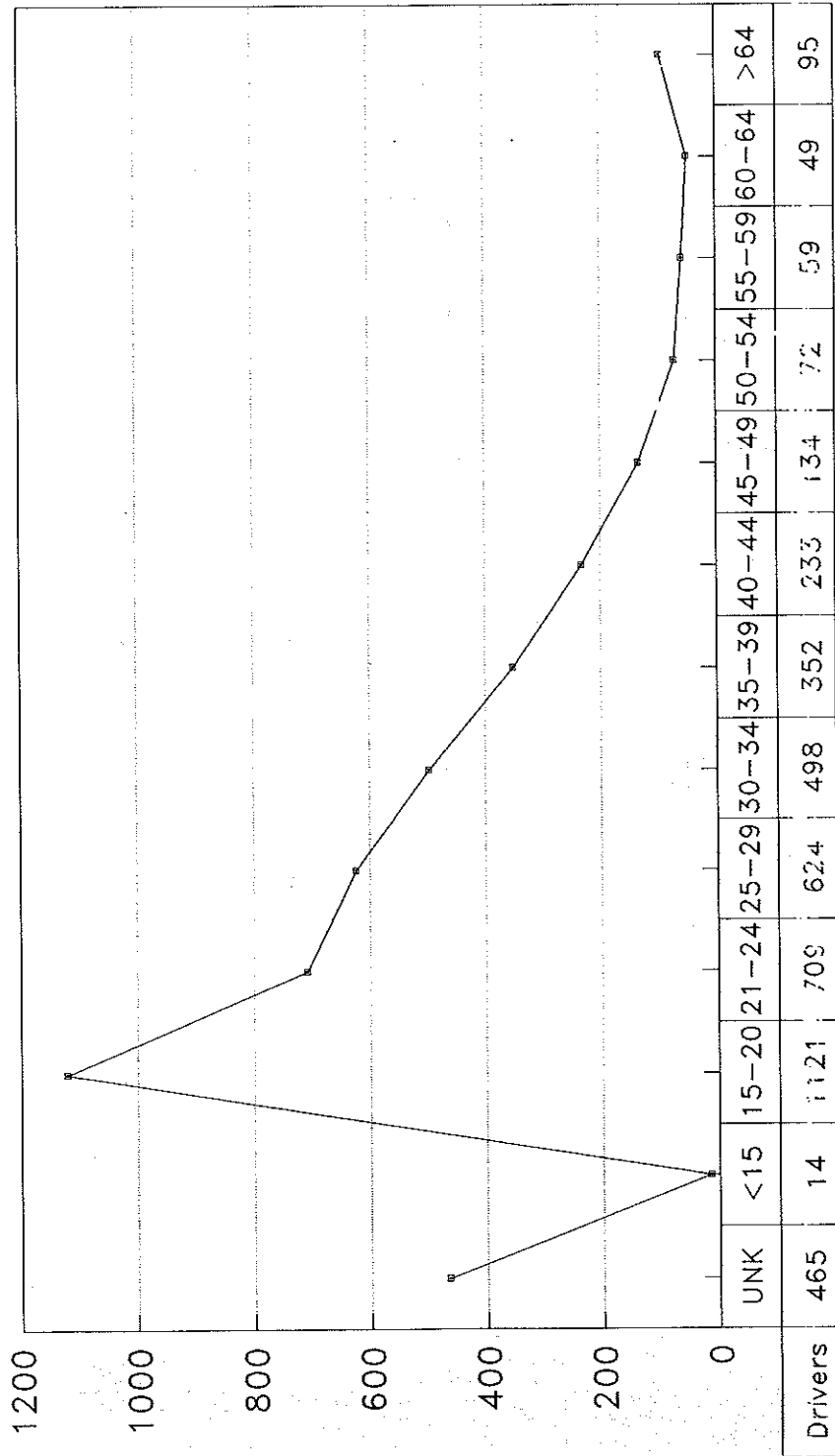

— Drivers

DRIVERS 4,425
SPEEDD

HOLIDAY PERIODS

	BEGAN 6PM	ENDED MIDNIGHT	TOTAL HOURS	CRASHES*		DEATHS		INJURIES*	
				F&I	AIC	ALL	AIC	ALL	AIC
MARDI GRAS									
1992	2/28	3/03	102	690	119	9	5	1,210	225
1991	2/08	2/12	102	507	103	7	5	889	197
1990	2/23	2/27	102	631	131	14	8	1,195	232
MEMORIAL DAY									
1992	5/22	5/25	78	447	70	9	4	771	126
1991	5/24	5/27	78	406	75	11	7	750	158
1990	5/25	5/28	78	489	96	9	2	860	173
4TH OF JULY									
1992	7/02	7/05	78	364	60	7	1	692	102
1991	7/03	7/07	102	598	125	15	6	1,092	222
1990	7/03	7/04	30	195	39	1	0	355	81
LABOR DAY									
1992	9/04	9/07	78	349	77	8	2	623	153
1991	8/30	9/02	78	443	97	6	4	817	158
1990	8/31	9/03	78	468	115	16	9	823	214
THANKSGIVING									
1992	11/25	11/29	102	352	68	7	4	632	112
1990	11/21	11/25	102	440	101	15	7	801	190
1991	11/27	12/01	102	483	106	12	6	855	187
CHRISTMAS									
1992	12/23	12/27	102	461	87	11	3	831	164
1991	12/23	12/25	54	34	58	8	3	398	96
1990	12/21	12/25	102	526	87	16	5	887	136
NEW YEARS									
1992	12/30	1/03	102	304	63	8	2	482	103
1991	12/29	1/01	78	312	73	13	7	517	118
1990	12/28	1/01	102	424	85	15	6	697	135

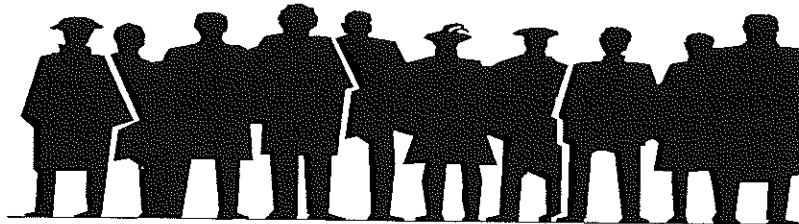

TRAIN CRASHES

	1989	1990	1991	1992
F&I ACCIDENTS				
URBAN	42	55	40	45
RURAL	<u>55</u>	<u>51</u>	<u>39</u>	<u>46</u>
	97	106	79	91
INJURY ACCIDENTS	80	85	73	75
FATAL ACCIDENTS	<u>17</u>	<u>21</u>	<u>06</u>	<u>16</u>
	97	106	79	91
INJURY AIA	29	16	05	5
FATAL AIA	<u>8</u>	<u>3</u>	<u>00</u>	<u>4</u>
	37	19	05	9
INJURIES	137	141	108	308
DEATHS	22	26	06	19

MOTORCYCLE CRASHES

RIDERS

1992

<u>RIDER INJURY</u>	<u>1990</u>	<u>1991</u>	<u>1992</u>
FATAL	45	34	39
CRITICAL	21	13	22
SERIOUS	42	37	46
SEVERE	70	71	72
MODERATE	353	270	344
MINOR	573	396	484
NO INJURY	60	52	59
TOTAL	<u>1,164</u>	<u>873</u>	<u>1,066</u>
<u>HELMET USE</u>			
USED	686	532	649
NOT USED	<u>478</u>	<u>341</u>	<u>417</u>
TOTAL	<u>1,164</u>	<u>873</u>	<u>1,066</u>
<u>% HELMET USE</u>			
USED	58.9%	60.9%	60.9%
NOT USED	41.1%	39.9%	39.9%

1992 OBSERVATIONAL SURVEY - HELMET USE BY REGION

REGION	1	N/A	N/A	96%
	2	N/A	N/A	96%
	3	N/A	N/A	100%
	4	N/A	N/A	100%
	5	N/A	N/A	100%
	6	N/A	N/A	100%
	7	N/A	N/A	100%
	8	<u>N/A</u>	<u>N/A</u>	<u>100%</u>
TOTAL		N/A	N/A	98%

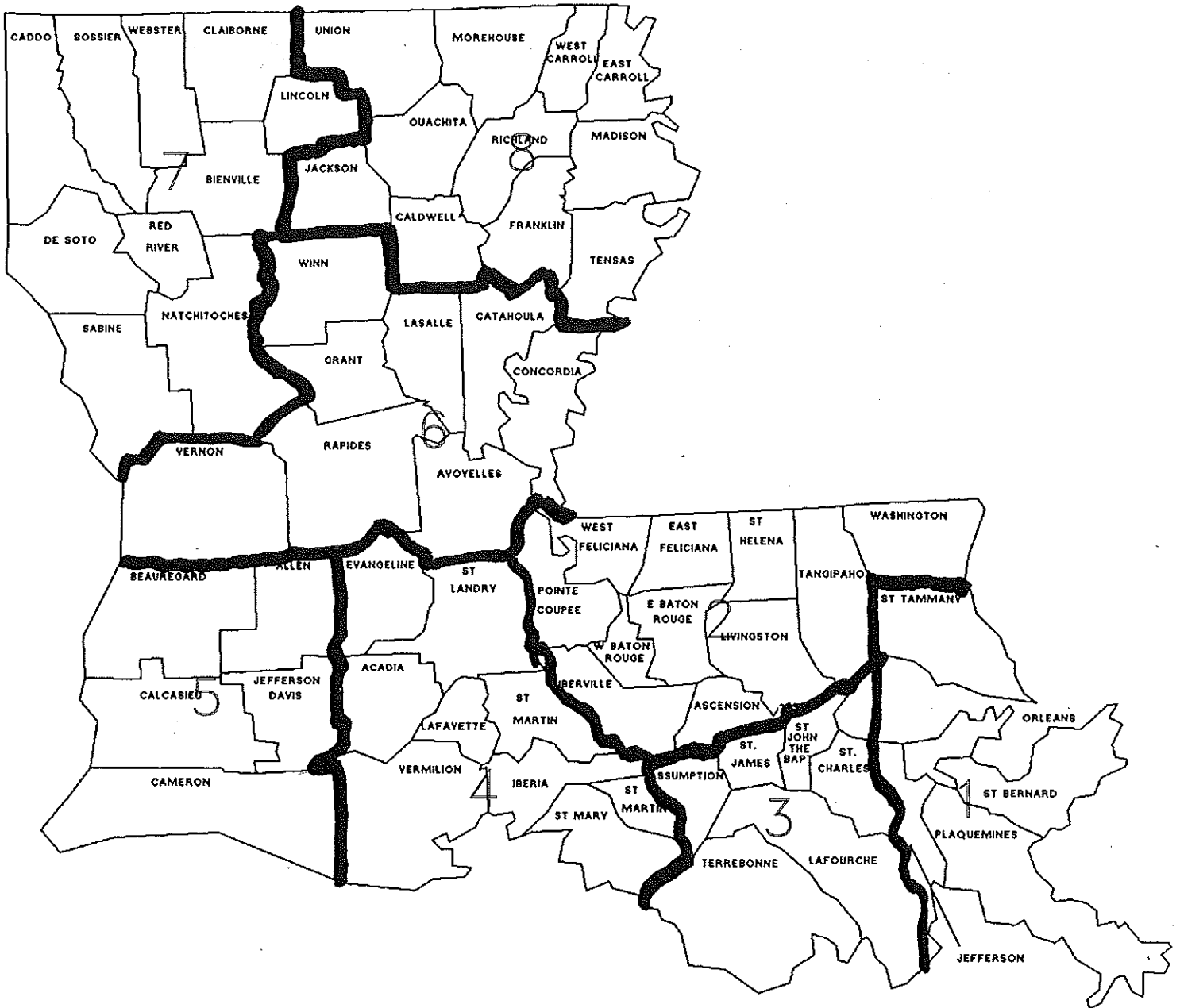

SEAT BELT SURVEY REGIONS

SAFETY BELT/CHILD RESTRAINT USAGE

USAGE AGE 5 AND OVER

	1986	1987	1988	1989	1990	1991	1992	1993
1	12%	31%	33%	27%	41%	32%	55%	41%
2	12%	26%	28%	43%	42%	42%	50%	51%
3	11%	38%	46%	43%	37%	44%	46%	55%
4	16%	38%	48%	54%	55%	61%	52%	64%
5	19%	47%	36%	40%	61%	50%	62%	52%
6	17%	39%	32%	40%	42%	46%	40%	52%
7	15%	47%	39%	48%	30%	47%	51%	45%
8	5%	27%	29%	33%	28%	34%	54%	55%
LA	12%	35%	36%	41%	43%	42%	50%	48%

AGES UNDER 5 YEARS

	1986	1987	1988	1989	1990	1991	1992	1993
1	32%	61%	35%	51%	30%	35%	85%	48%
2	43%	57%	38%	44%	42%	56%	70%	61%
3	51%	34%	49%	39%	23%	34%	50%	95%
4	48%	44%	46%	57%	75%	73%	64%	41%
5	53%	53%	46%	68%	61%	64%	54%	60%
6	31%	35%	26%	17%	25%	34%	44%	47%
7	64%	47%	30%	32%	60%	52%	85%	54%
8	63%	27%	21%	41%	36%	25%	34%	36%
LA	46%	43%	37%	44%	40%	43%	64%	50%

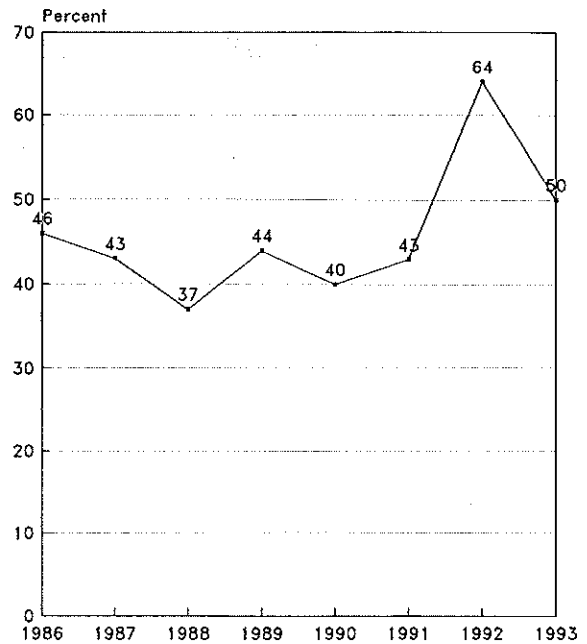
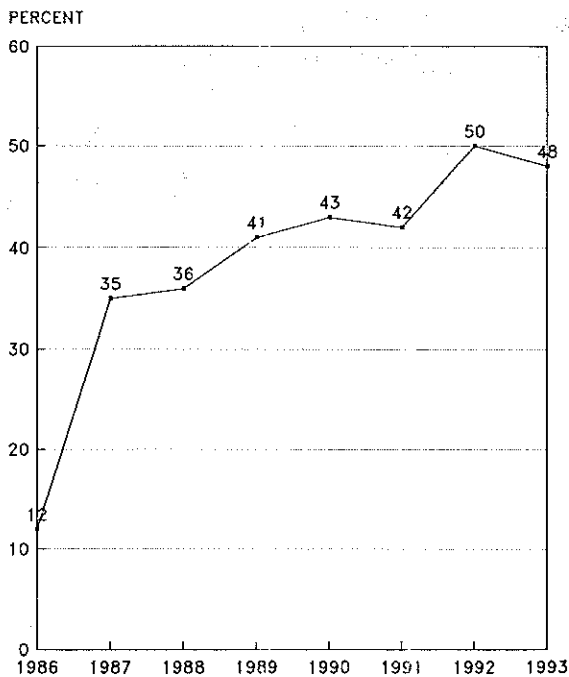

Type of Collision in Fatal & Injury Crashes

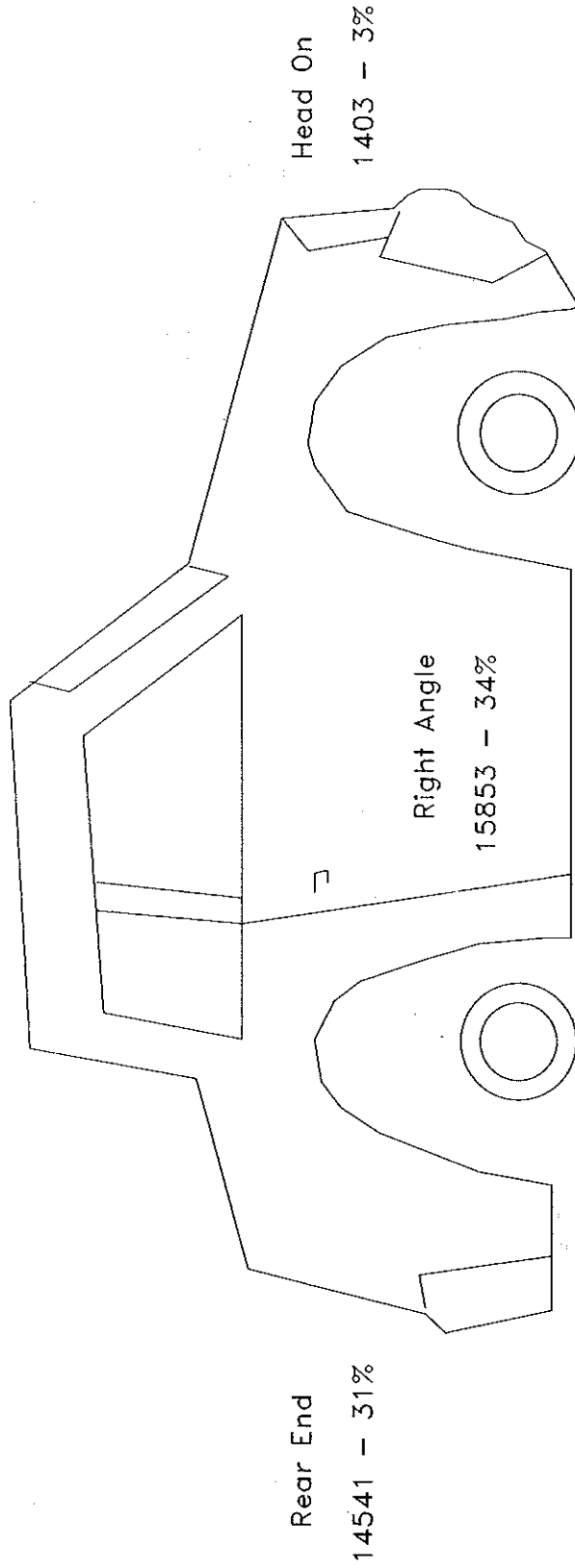

Collision Type	Count	Percentage
Rear End	14541	31%
Right Angle	15853	34%
Head On	1403	3%
Sideswipe, Same Direction	1284	3%
Sideswipe, Opposite Direction	988	2%
Non-Collision	7362	16%
Not Stated	161	0%
Other	5048	11%

CONTRIBUTING FACTORS IN F & I CRASHES

PRIMARY CONTRIBUTING FACTORS

	COUNT	PERCENT
<u>Violations</u>	<u>30,396</u>	<u>65.2</u>
Movement Prior	7,811	16.7
Driver Condition	4,848	10.4
Vehicle Condition	744	1.6
Pedestrian Action	689	1.5
All Other Factors	2,152	4.6
TOTAL	46,640	100.0

VIOLATIONS

*Failure to Yield	9,935	21.0
*Following Too Close	4,946	10.4
<u>Driver Condition</u>	<u>3,247</u>	<u>6.9</u>
Disregarded Traffic Control	2,619	5.5
Exceeding Stated/Safe Speed	1,521	3.2
Turning Maneuver	1,510	3.2
Driver Left Of Center	816	1.7
All Other Violations	22,776	48.1
TOTAL	88,614	100.0
No Violations	41,244	

*See "Type of Collision"

CONDITION OF DRIVER

	COUNT	PERCENT
Inattentive or Distracted	21,842	24.6
HBD- Not Impaired	1,228	1.4
HBD-Impaired	4,262	4.8
Drug Impaired	1,934	2.2
Apparently Asleep	905	1.0
Other Conditions	523	0.6
Unknown Conditions	14,001	15.8
Normal Or Not Stated	43,919	49.6
TOTAL	88,614	100.0

1992 Traffic Convictions by Violation

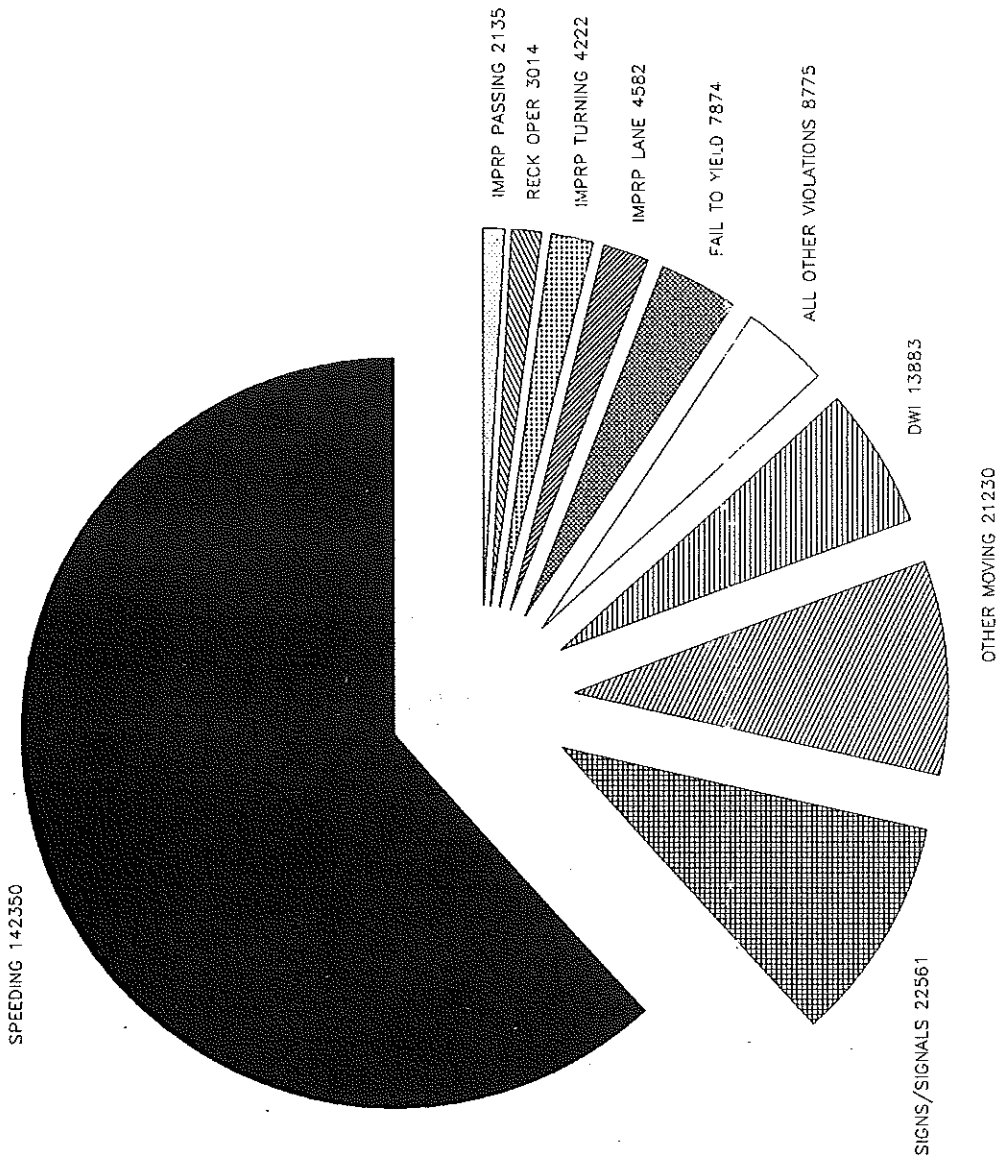

Source: DMS DROR01 11/24/93

DWI Convictions Including Suspensions

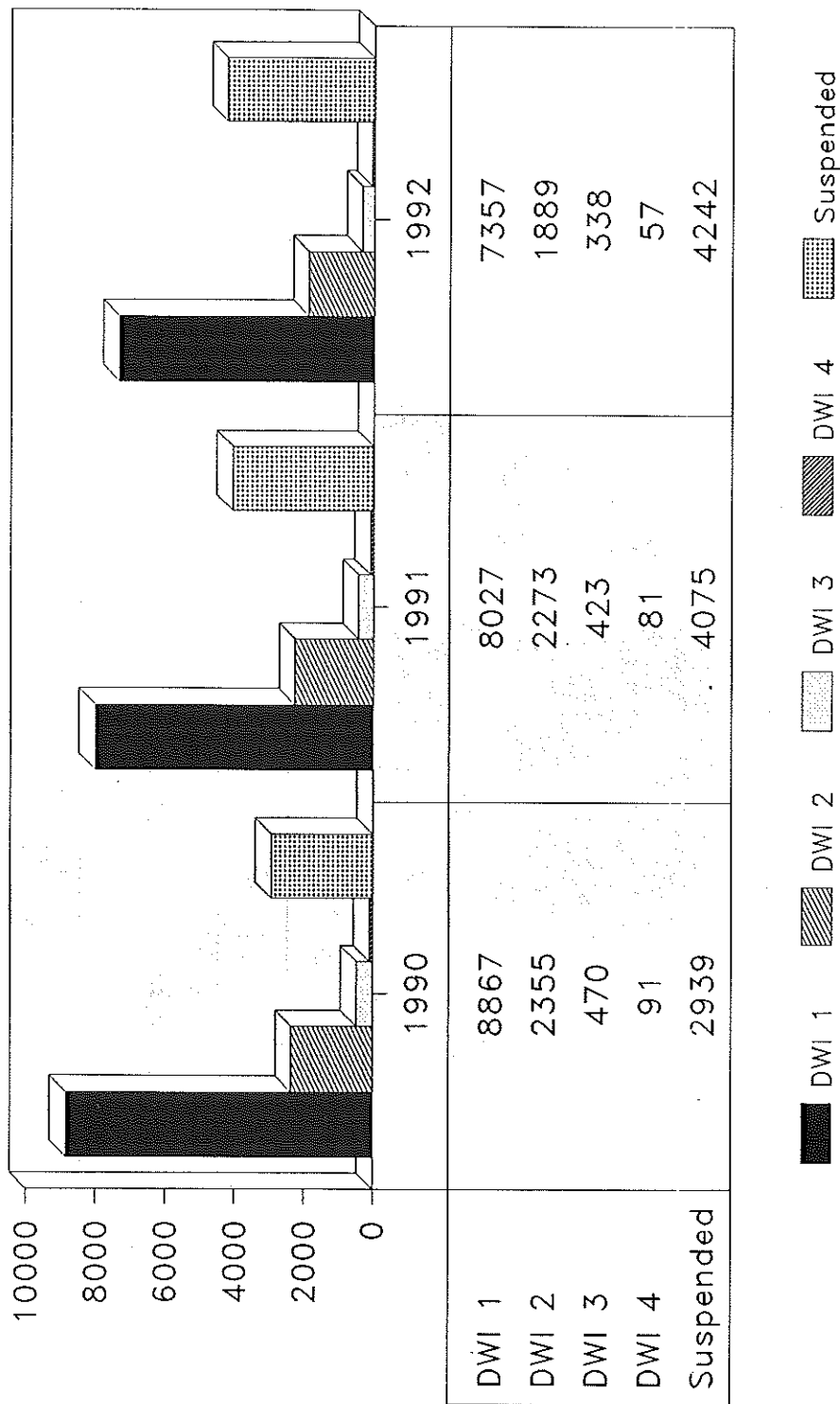

Source: DMS DR0R01 11/24/93

DWI Arrests and Convictions

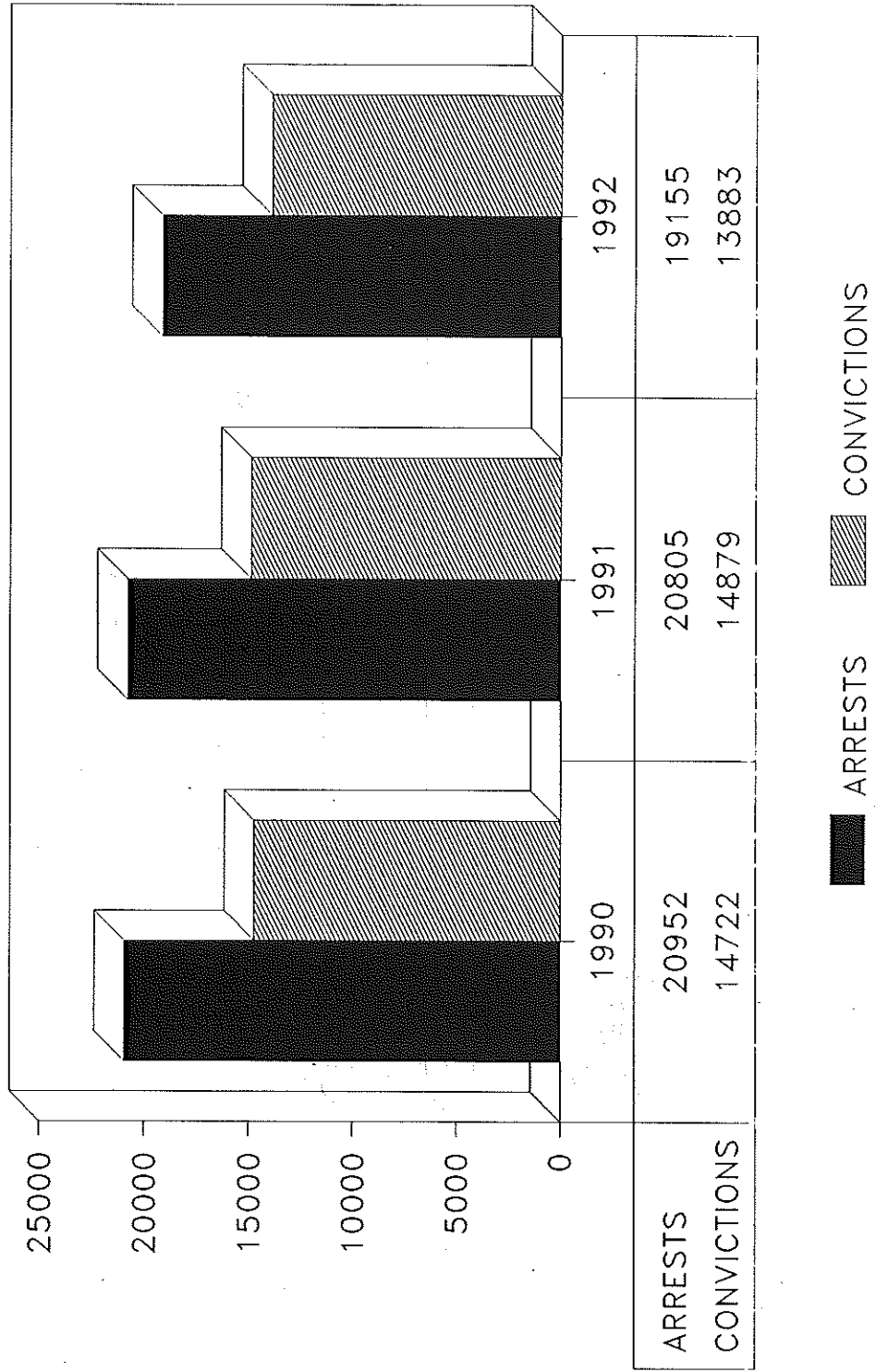

NOTE: Convictions may not have occurred in the same year as arrests.
 Source: DMS DRQ01 11/24/93

1992 DWI Arrests by Submits, Refusals and Pending Tests

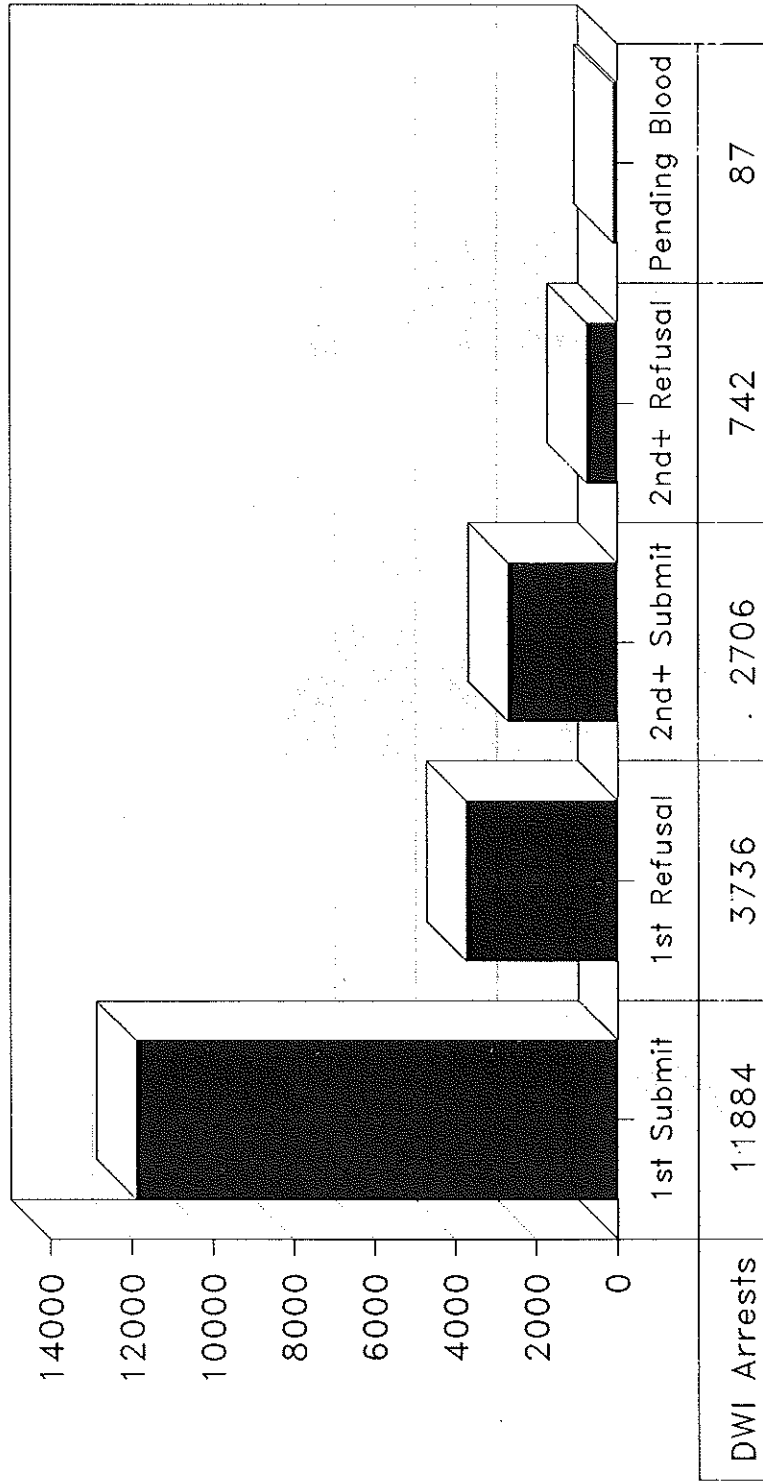

Source: DMS DRQR01 11/24/93

Percent of Refusals to Test for DWI

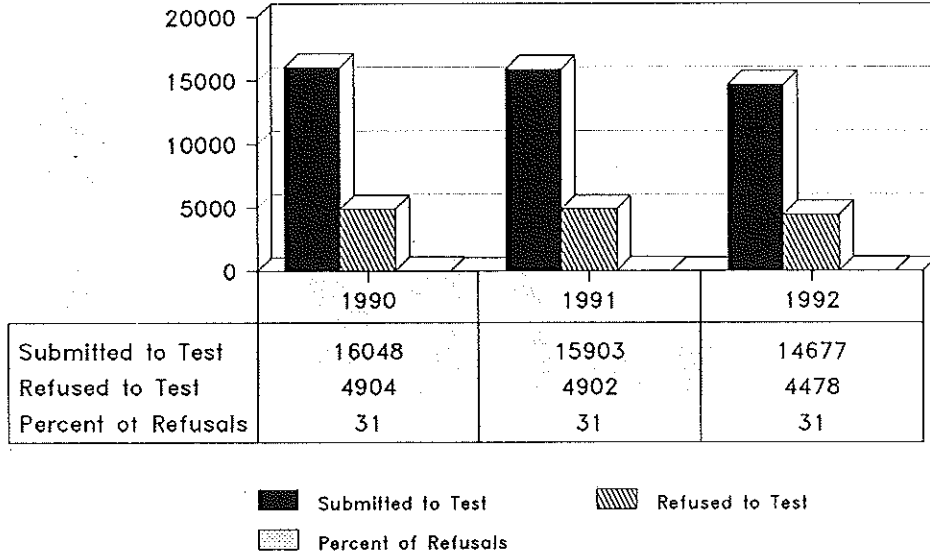

Source: DMS DR0R01 11/24/93

Percent of DWI Repeat Offenders

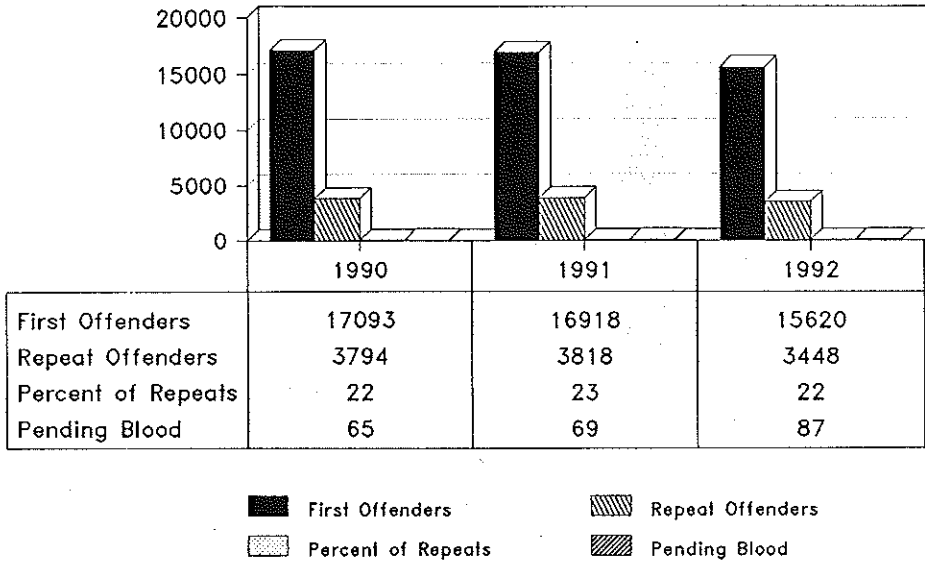

Source: DMS DR0R01 11/24/93 Arrests

Blood Alcohol Concentrations (BACs) for DRIVERS TESTED in F & I Crashes

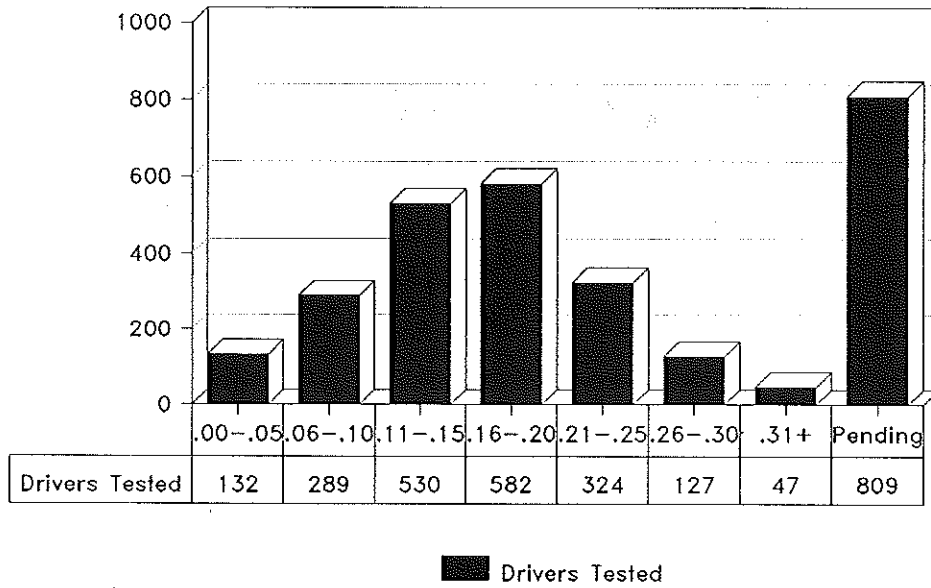

Source: LHSC HSI380 03/12/94

Blood Alcohol Concentrations (BACs) for PEDESTRIANS Tested in F & I Crashes

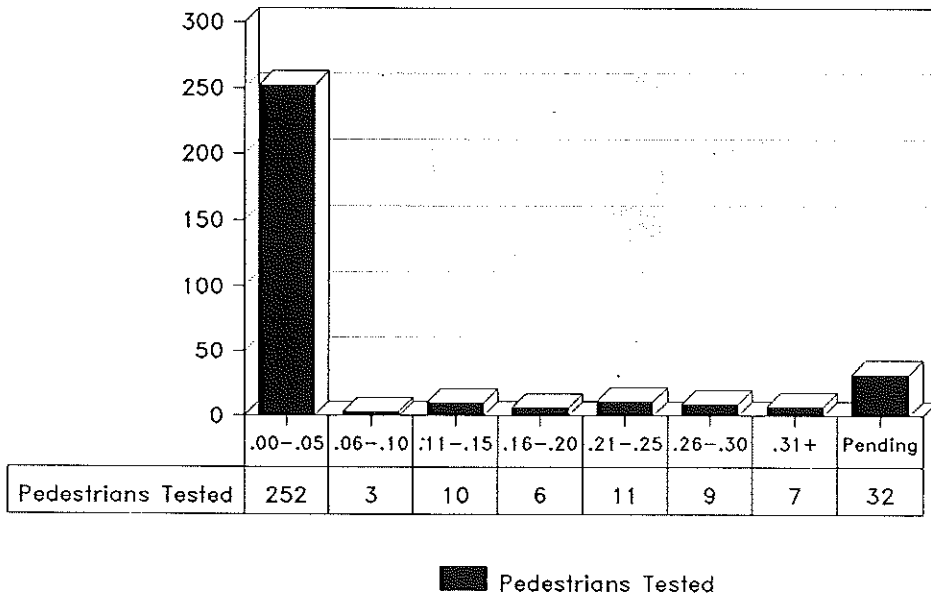

Source: LHSC HSI380 03/12/94

PARISH RANKING

FATAL AND INJURY CRASHES

PARISH NAME	RATE/POP 10,000	PARISH NAME	RATE/POP 10,000
1 EAST BATON ROUGE	162.54	33 JEFFERSON DAVIS	86.32
2 WEST BATON ROUGE	147.42	34 POINTE COUPEE	85.78
3 TERREBONNE	141.58	35 ST. BERNARD	84.98
4 ASCENSION	135.57	36 BEAUREGARD	84.67
5 LAFAYETTE	129.57	37 CALDWELL	82.57
6 OUACHITA	125.95	38 UNION	80.68
7 TANGIPAHOA	125.09	39 LINCOLN	80.34
8 RAPIDES	124.24	40 EAST FELICIANA	78.65
9 EVANGELINE	123.12	41 AVOUELLES	78.52
10 JEFFERSON	122.28	42 ST. MARY	77.97
11 IBERIA	120.06	43 PLAQUEMINES	76.95
12 CALCASIEU	117.43	44 WINN	74.23
13 ORLEANS	116.28	45 ALLEN	73.58
14 ST. MARTIN	115.73	46 BIENVILLE	72.50
15 LAFOURCHE	106.28	47 DESOTO	71.54
16 ST. CHARLES	104.01	48 MADISON	71.20
17 ST. TAMMANY	102.42	49 CATAHOULA	69.37
18 ASSUMPTION	101.32	50 LASALLE	69.34
19 CADDO	100.64	51 EAST CARROLL	62.87
20 VERMILION	100.60	52 GRANT	62.86
21 BOSSIER	99.88	53 VERNON	62.78
22 ACADIA	98.21	54 CLAIBORNE	62.35
23 ST. LANDRY	97.14	55 CONCORDIA	60.10
24 MOREHOUSE	94.67	56 RICHLAND	56.80
25 IBERVILLE	94.19	57 SABINE	56.64
26 NATCHITOCHE	93.46	58 JACKSON	49.68
27 ST. JOHN	92.26	59 ST. HELENA	49.65
28 WEBSTER	92.16	60 RED RIVER	48.99
29 ST. JAMES	90.43	61 WEST CARROLL	45.45
30 LIVINGSTON	89.50	62 WEST FELICIANA	42.64
31 CAMERON	88.55	63 TENSAS	38.03
32 WASHINGTON	86.81	64 FRANKLIN	15.18

PARISH RANKING

FATAL AND INJURY CRASHES

PARISH NAME	RATE/LD 10,000	PARISH NAME	RATE/LD 10,000
1 EAST BATON ROUGE	252.27	33 POINTE COUPEE	139.86
2 ORLEANS	243.08	34 LIVINGSTON	139.60
3 WEST BATON ROUGE	226.98	35 EAST FELICIANA	138.53
4 EVANGELINE	222.83	36 WASHINGTON	135.38
5 TERREBONNE	214.53	37 JEFFERSON DAVIS	132.50
6 RAPIDES	208.81	38 WINN	128.04
7 ST. MARTIN	206.07	39 AVOYELLES	127.92
8 ASCENSION	205.47	40 DESOTO	127.46
9 OUACHITA	205.15	41 ST. BERNARD	127.19
10 TANGIPAHOA	199.63	42 VERNON	126.71
11 LAFAYETTE	196.14	43 ST. MARY	125.14
12 IBERIA	193.85	44 BEAUREGARD	125.12
13 ASSUMPTION	184.00	45 PLAQUEMINES	123.90
14 JEFFERSON	180.98	46 EAST CARROLL	122.49
15 LAFOURCHE	175.57	47 UNION	121.01
16 CALCASIEU	170.91	48 CALDWELL	120.14
17 NATCHITOCHE	168.97	49 CLAIBORNE	117.20
18 CADDO	164.13	50 ALLEN	113.87
19 IBERVILLE	164.04	51 CATAHOULA	111.63
20 ACADIA	163.88	52 WEST FELICIANA	108.06
21 MOREHOUSE	160.64	53 GRANT	106.80
22 BOSSIER	160.45	54 LASALLE	97.93
23 ST. CHARLES	158.06	55 CONCORDIA	97.66
24 ST. JOHN	154.07	56 ST. HELENA	96.65
25 VERMILION	153.66	57 RICHLAND	94.35
26 ST. JAMES	148.82	58 SABINE	88.28
27 ST. LANDRY	148.01	59 JACKSON	86.32
28 MADISON	147.60	60 RED RIVER	83.18
29 LINCOLN	146.93	61 WEST CARROLL	67.65
30 CAMERON	143.48	62 TENSAS	67.43
31 ST. TAMMANY	141.36	63 FRANKLIN	25.95
32 WEBSTER	140.22	64 BIENVILLE	12.12

PARISH RANKING

ALCOHOL INVOLVED CRASHES

PARISH	ALCOHOL CRASHES	POPULATION	RATE/POP 10,000	RANK	LICENSED DRIVERS	RATE/LD 10,000	RANK
1 Acadia	81	55,882	14.5	23	33,541	24.1	22
2 Allen	26	21,226	12.2	34	13,696	19.0	40
3 Ascension	107	58,214	18.4	8	38,392	27.9	11
4 Assumption	46	22,753	20.2	4	12,557	36.6	3
5 Avoyelles	68	39,159	17.4	11	23,992	28.3	9
6 Beauregard	33	30,083	11.0	43	20,288	16.3	52
7 Bienville	26	15,979	16.3	15	9,569	27.2	14
8 Bossier	103	86,088	12.0	37	53,582	19.2	39
9 Caddo	278	248,253	11.2	42	152,224	18.3	43
10 Calcasieu	334	168,134	19.9	5	115,525	28.9	8
11 Caldwell	27	9,810	27.5	1	6,742	40.0	2
12 Cameron	23	9,260	24.8	2	5,715	40.2	1
13 Catahoula	13	11,065	11.7	38	6,898	18.8	41
14 Claiborne	19	17,405	10.9	44	9,044	21.0	29
15 Concordia	33	20,828	15.8	17	12,834	25.7	19
16 Desoto	26	25,346	10.3	50	14,254	18.2	45
17 EBR	391	380,105	10.3	49	244,954	16.0	55
18 E. Carroll	10	9,709	10.3	48	4,982	20.1	35
19 E. Feliciana	30	19,211	15.6	18	10,904	27.5	13
20 Evangeline	56	33,274	16.8	12	18,445	30.4	6
21 Franklin	10	22,387	4.5	62	13,084	7.6	63
22 Grant	15	17,526	8.6	55	10,349	14.5	56
23 Iberia	114	68,297	16.7	13	42,275	27.0	15
24 Iberville	47	31,049	15.1	19	17,813	26.4	18
25 Jackson	13	15,705	8.3	56	9,036	14.4	57
26 Jefferson	857	448,306	19.1	6	302,939	28.3	10
27 Jeff. Davis	51	30,722	16.6	14	20,017	25.5	20
28 Lafayette	241	164,762	14.6	22	108,857	22.1	24
29 Lafourche	153	85,860	17.8	9	51,972	29.4	7
30 LaSalle	19	13,662	13.9	28	9,719	19.5	36
31 Lincoln	37	41,745	8.9	53	22,832	16.2	53
32 Livingston	95	70,526	13.5	29	45,169	21.0	28
33 Madison	11	12,463	8.8	54	6,026	18.3	44

PARISH RANKING

ALCOHOL INVOLVED CRASHES

PARISH	ALCOHOL CRASHES	POPULATION	RATE/POP 10,000	RANK	LICENSED DRIVERS	RATE/LD 10,000	RANK
34 Morehouse	32	31,938	10.0	51	18,752	17.1	50
35 Natchitoches	54	36,689	14.7	21	20,306	26.6	17
36 Orleans	189	496,938	3.8	63	237,731	8.0	62
37 Ouachita	149	142,191	10.5	46	87,271	17.1	49
38 Plaquemines	31	25,575	12.1	35	15,910	19.5	37
39 Pt. Coupee	26	22,540	11.5	40	13,805	18.8	42
40 Rapides	151	131,556	11.5	41	78,303	19.3	38
41 Red River	6	9,387	6.4	60	5,526	10.9	60
42 Richland	25	20,629	12.1	36	12,362	20.2	33
43 Sabine	18	22,646	7.9	58	14,467	12.4	59
44 St. Bernard	60	66,631	9.0	52	44,491	13.5	58
45 St. Charles	61	42,437	14.4	25	27,885	21.9	27
46 St. Helena	14	9,874	14.2	27	5,066	27.6	12
47 St. James	30	20,879	14.4	26	12,660	23.7	23
48 St. John	53	39,996	13.3	31	23,952	22.1	25
49 St. Landry	107	80,331	13.3	30	52,665	20.3	32
50 St. Martin	83	43,978	18.9	7	24,739	33.6	4
51 St. Mary	76	58,086	13.1	32	36,204	21.0	30
52 St. Tammany	214	144,508	14.8	20	104,687	20.4	31
53 Tangipahoa	108	85,709	12.6	33	53,701	20.1	34
54 Tensas	2	7,103	2.8	64	4,004	5.0	64
55 Terrebonne	202	96,982	20.8	3	64,048	31.5	5
56 Union	22	20,690	10.6	45	13,768	16.0	54
57 Vermilion	72	50,055	14.4	24	32,814	21.9	26
58 Vernon	50	61,961	8.1	57	30,715	16.3	51
59 Washington	50	43,185	11.6	39	27,728	18.0	46
60 Webster	68	41,989	16.2	16	27,593	24.6	21
61 WBR	34	19,419	17.5	10	12,620	26.9	16
62 W. Carroll	7	12,093	5.8	61	8,128	8.6	61
63 W. Feliciana	9	12,915	7.0	59	5,086	17.7	48
64 Winn	17	16,269	10.4	47	9,449	18.0	47
Not Stated					18	0.0	
STATE TOTAL	5,413	4,219,973	12.8		2,594,680	20.9	

POPULATION, LICENSED DRIVERS AND REGISTERED VEHICLES

PARISH	POPULATION	LICENSED DRIVERS	REGISTERED VEHICLES
1-Acadia	55,882	33,541	62,135
2-Allen	21,226	13,696	23,407
3-Ascension	58,214	38,392	81,005
4-Assumption	22,753	12,557	26,936
5-Avoyelles	39,159	23,992	44,501
6-Beauregard	30,083	20,288	35,887
7-Bienville	15,979	9,569	19,919
8-Bossier	86,088	53,582	113,118
9-Caddo	248,253	152,224	253,100
10-Calcasieu	168,134	115,525	185,778
11-Caldwell	9,810	6,742	20,773
12-Cameron	9,260	5,715	11,625
13-Catahoula	11,065	6,898	12,245
14-Claiborne	17,405	9,044	21,040
15-Concordia	20,828	12,834	23,064
16-Desoto	25,346	14,254	26,203
17-E. Baton Rouge	380,105	244,954	417,065
18-E. Carroll	9,709	4,982	8,514
19-E. Feliciana	19,211	10,904	17,920
20-Evangeline	33,274	18,445	29,951
21-Franklin	22,387	13,084	22,886
22-Grant	17,526	10,349	24,835
23-Iberia	68,297	42,275	68,742
24-Iberville	31,049	17,813	28,885
25-Jackson	15,705	9,036	14,674
26-Jefferson	448,306	302,939	519,369
27-Jeff Davis	30,722	20,017	27,302
28-Lafayette	164,762	108,857	173,541
29-Lafourche	85,860	51,972	80,979
30-LaSalle	13,662	9,719	16,414
31-Lincoln	41,745	22,832	39,374
32-Livingston	70,526	45,169	78,105
33-Madison	12,463	6,026	10,700
34-Morehouse	31,938	18,752	39,395
35-Natchitoches	36,689	20,306	35,818
36-Orleans	496,938	237,731	329,640
37-Ouachita	142,191	87,271	133,167
38-Plaquemines	25,575	15,910	26,837
39-Pt. Coupee	22,540	13,805	21,474
40-Rapides	131,556	78,303	115,681
41-Red River	9,387	5,526	8,447
42-Richland	20,629	12,362	17,728
43-Sabine	22,646	14,467	25,780
44-St. Bernard	66,631	44,491	67,330
45-St. Charles	42,437	27,885	46,655
46-St. Helena	9,874	5,066	10,940
47-St. James	20,879	12,660	18,472
48-St. John	39,996	23,952	32,338
49-St. Landry	80,331	52,665	71,396
50-St. Martin	43,978	24,739	32,464
51-St. Mary	58,086	36,204	48,505
52-St. Tammany	144,508	104,687	177,077
53-Tangipahoa	85,709	53,701	79,289
54-Tensas	7,103	4,004	6,752
55-Terrebonne	96,982	64,048	83,166
56-Union	20,690	13,768	22,031
57-Vermilion	50,055	32,814	44,486
58-Vernon	61,961	30,715	60,390
59-Washington	43,185	27,728	37,807
60-Webster	41,989	27,593	42,836
61-W. Baton Rouge	19,419	12,620	21,626
62-W. Carroll	12,093	8,128	12,398
63-W. Feliciana	12,915	5,086	10,360
64-Winn	16,269	9,449	15,413
Not Stated		18	
TOTAL	4,219,973	2,594,680	4,235,689

Sources: 1990 Census; La Office of Motor Vehicles, 1992

LOUISIANA HIGHWAY SAFETY COMMISSION
 FATAL AND INJURY ACCIDENT DATA
 =====> 1992 <=====

PAGE 1

PARISH NAME	AREA	--ACCIDENTS--		--FATALITIES--		--INJURIES--		
		ALL	ALC	ALL	ALC	ALL	ALC	
ACADIA	RURAL	280	58	32	6	490	101	
	CHURCH POINT	44	5	2	0	67	6	
	CROWLEY	134	9	3	0	194	13	
	ESTERWOOD	1	0	0	0	1	0	
	IOTA	7	2	0	0	9	2	
	MERMENTAU	1	0	0	0	1	0	
	RAYNE	76	7	3	1	134	11	
PARISH TOTALS	549	81	40	6	905	133		
ALLEN	RURAL	71	17	17	4	112	23	
	ELIZABETH	2	0	0	0	3	0	
	KINDER	19	3	3	0	23	3	
	OAKDALE	63	6	6	0	97	11	
	O245	1	0	0	0	1	0	
	PARISH TOTALS	156	26	26	4	236	37	
	ASCENSION	RURAL	554	89	67	9	989	158
DONALDSONVILLE		83	7	11	0	150	17	
GONZALES		145	11	14	2	270	17	
SORRENTO		7	0	3	0	18	0	
PARISH TOTALS		789	107	95	11	1,427	192	
ASSUMPTION		RURAL	221	45	25	3	392	72
		NAPOLEONVILLE	9	1	0	0	12	3
	PARISH TOTALS	230	46	25	3	404	75	
	AVDYELLES	RURAL	181	51	31	8	294	73
		BUNKIE	38	2	5	0	72	10
		COTTONPORT	7	0	0	0	15	0
		HESSMER	3	1	1	0	5	3
MANSURA		3	1	0	0	4	1	
MARKSVILLE		67	13	9	0	143	33	
MOREAUVILLE		3	0	0	0	7	0	
SIMMESPORT		4	0	0	0	8	0	
O591		1	0	0	0	4	0	
PARISH TOTALS		307	68	46	8	552	120	
BEAUREGARD	RURAL	128	24	36	2	208	42	
	MERRYVILLE	4	0	0	0	8	0	
	DERIDDER	122	9	4	1	205	12	
	PARISH TOTALS	254	33	40	3	421	54	

DATA AVAILABLE AS OF 03/11/94

ALC FATALITIES + SPD FATALITIES MAY BE GREATER THAN THE
 TOTAL FATALITIES SINCE A CRASH MAY BE ALC AND SPD INVOLVED

LOUISIANA HIGHWAY SAFETY COMMISSION
 FATAL AND INJURY ACCIDENT DATA
 =====> 1992 <=====

PAGE
2

PARISH NAME	AREA	--ACCIDENTS--			--FATALITIES--			--INJURIES--		
		ALL	ALC	SPD	ALL	ALC	SPD	ALL	ALC	SPD
BIENVILLE	RURAL	110	26	33	6	1	4	155	35	47
	ARCADIA	2	0	1	1	0	0	1	0	1
	CASTOR	1	0	1	0	0	0	1	0	1
	GIBSLAND	2	0	1	0	0	0	5	0	4
	JAMESTOWN	1	0	1	0	0	0	1	0	1
PARISH TOTALS	116	26	37	7	1	4	163	35	54	
BOSSIER	RURAL	209	43	62	5	1	5	332	72	97
	BENTON	5	0	0	0	0	0	6	0	0
	BOSSIER CITY	626	57	67	9	3	3	955	92	102
	HAUGHTON	7	2	0	1	0	0	8	2	0
	PLAIN DEALING	9	1	0	0	0	0	15	1	0
O809	4	0	1	0	0	0	5	0	2	
PARISH TOTALS	860	103	130	15	4	8	1,321	167	201	
CADD0	RURAL	254	46	62	16	3	5	415	72	106
	BELCHER	2	1	0	1	1	0	3	2	0
	BLANCHARD	5	0	2	0	0	0	10	0	4
	GILLIAM	1	0	0	0	0	0	2	0	0
	GREENWOOD	6	1	1	0	0	0	8	2	1
	HOSSTON	3	2	1	0	0	0	4	2	1
	MOORINGSPO	2	0	1	0	0	0	2	0	1
	RODESSA	2	2	1	0	0	0	2	2	1
	VIVIAN	11	0	1	0	0	0	18	0	1
	O914	2	0	1	0	0	0	3	0	1
	SHREVEPORT	2,210	226	129	24	2	7	3,659	393	217
PARISH TOTALS	2,498	278	199	41	6	12	4,126	473	333	
CALCASIEU	RURAL	591	130	137	23	8	7	961	200	217
	DE QUINCY	14	2	1	0	0	0	25	3	2
	IOWA	10	3	0	0	0	0	14	3	0
	LAKE CHARLES	1,087	176	11	4	0	1	1,766	294	18
	SULPHUR	204	19	7	0	0	0	301	27	7
VINTON	15	1	0	0	0	0	20	2	0	
WESTLAKE	53	3	6	1	1	0	89	4	14	
PARISH TOTALS	1,974	334	162	29	9	8	3,176	533	258	
CALDWELL	RURAL	69	25	18	8	4	3	134	51	31
	COLUMBIA	10	1	1	0	0	0	15	1	2
	GRAYSON	2	1	2	0	0	0	2	1	0
PARISH TOTALS	81	27	21	8	4	3	151	53	35	

DATA AVAILABLE AS OF 03/11/94

ALC FATALITIES + SPD FATALITIES MAY BE GREATER THAN THE
 TOTAL FATALITIES SINCE A CRASH MAY BE ALC AND SPD INVOLVED

LOUISIANA HIGHWAY SAFETY COMMISSION
 FATAL AND INJURY ACCIDENT DATA
 =====> 1992 <=====

PAGE 3

PARISH NAME	AREA	--ACCIDENTS--			--FATALITIES--			--INJURIES--		
		ALL	ALC	SPD	ALL	ALC	SPD	ALL	ALC	SPD
CAMERON	RURAL	80	21	8	2	0	1	135	34	18
	1209	2	2	0	0	0	0	7	7	0
	PARISH TOTALS	82	23	8	2	0	1	142	41	18
CATAHOULA	RURAL	46	8	15	5	2	0	74	14	25
	HARRISONBURG	1	1	0	0	0	0	1	1	0
	JONESVILLE	28	4	4	0	0	0	53	6	8
	SICILY ISLAND	1	0	1	0	0	0	1	0	1
1309	1	0	1	0	0	0	1	0	1	
PARISH TOTALS	77	13	21	5	2	0	130	21	35	
CLAIBORNE	RURAL	80	15	27	4	2	0	121	23	38
	HAYNESVILLE	19	3	5	0	0	0	30	5	8
	HOMER	4	0	2	0	0	0	4	0	2
	1409	3	1	2	0	0	0	11	6	10
PARISH TOTALS	106	19	36	4	2	0	166	34	58	
CONCORDIA	RURAL	87	28	26	4	3	3	134	40	39
	CLAYTON	1	1	0	0	0	0	1	1	0
	FERRIDAY	11	1	5	0	0	0	16	4	9
	RIDGECREST	1	0	0	0	0	0	3	0	0
	VIDALIA	25	3	0	0	0	0	38	7	0
	PARISH TOTALS	125	33	31	4	3	3	192	52	48
DE SOTO	RURAL	135	17	33	5	2	2	199	26	45
	LOGANSPOUT	4	1	1	1	0	0	4	1	1
	MANSFIELD	40	8	3	0	0	0	66	19	7
	SOUTH MANSFIELD	1	0	0	1	0	0	0	0	0
	STONEWALL	1	0	0	0	0	0	1	0	0
PARISH TOTALS	181	26	37	7	2	2	270	46	53	
EAST BATON ROUGE	RURAL	1,177	132	101	23	12	4	1,919	246	166
	BAKER	144	15	14	1	0	0	270	23	26
	BATON ROUGE	4,744	230	140	21	6	2	7,809	408	227
	ZACHARY	111	14	19	0	0	0	190	26	28
	1707	1	0	0	0	0	0	1	0	0
1720	1	0	0	0	0	0	1	0	0	
PARISH TOTALS	6,178	391	274	45	18	6	10,190	703	447	

DATA AVAILABLE AS OF 03/11/94

ALC FATALITIES * SPD FATALITIES MAY BE GREATER THAN THE
 TOTAL FATALITIES SINCE A CRASH MAY BE ALC AND SPD INVOLVED

LOUISIANA HIGHWAY SAFETY COMMISSION
 FATAL AND INJURY ACCIDENT DATA
 =====> 1992 <=====

PARISH NAME	AREA	--ACCIDENTS--		--FATALITIES--		--INJURIES--	
		ALL	ALC	ALL	ALC	ALL	ALC
EAST CARROLL	RURAL	26	9	3	0	44	17
	LAKE PROVIDENCE	35	1	0	0	68	1
	PARISH TOTALS	61	10	3	0	112	18
EAST FELICIANA	RURAL	129	28	17	5	241	46
	CLINTON	14	0	1	0	26	0
	JACKSON	3	1	0	0	13	4
	SLAUGHTER	4	1	0	0	4	1
	WILSON	1	0	0	0	1	0
	PARISH TOTALS	151	30	18	5	285	51
EVANGELINE	RURAL	182	33	22	6	302	53
	BASILE	4	1	1	0	8	1
	CHATAIGNIER	3	1	1	0	4	1
	MAMOU	54	3	3	0	98	6
	TURKEY CREEK	1	0	0	0	0	0
	VILLE PLATTE	160	18	6	1	301	46
	2020	5	0	0	0	6	0
	2084	1	0	0	0	3	0
	PARISH TOTALS	410	56	33	7	722	108
	FRANKLIN	RURAL	27	9	6	0	50
BASKIN		1	0	0	0	1	0
GILBERT		1	0	0	0	2	0
WINNSBORO		5	1	1	0	9	1
PARISH TOTALS		34	10	7	0	62	14
GRANT	RURAL	96	13	25	0	162	16
	COLFAX	5	0	1	0	8	0
	DRY PRONG	2	1	2	0	2	1
	MONTGOMERY	2	1	0	0	5	1
	POLLOCK	5	0	2	0	11	0
	PARISH TOTALS	110	15	30	0	188	18
IBERIA	RURAL	352	78	45	10	580	117
	JEANERETTE	26	3	2	0	48	6
	LOREAUVILLE	2	0	0	0	4	0
	NEW IBERIA	437	32	9	1	713	42
	2304	1	0	0	0	3	0
	DELCAMBRE	1	1	1	0	2	2
	2354	1	0	1	0	1	0
PARISH TOTALS	820	114	58	11	1,351	167	

ALC FATALITIES + SPD FATALITIES MAY BE GREATER THAN THE
 TOTAL FATALITIES SINCE A CRASH MAY BE ALC AND SPD INVOLVED

LOUISIANA HIGHWAY SAFETY COMMISSION
 FATAL AND INJURY ACCIDENT DATA
 =====> 1992 <=====

PARISH NAME	AREA	--ACCIDENTS--			--FATALITIES--			--INJURIES--		
		ALL	ALC	SPD	ALL	ALC	SPD	ALL	ALC	SPD
IBERVILLE	RURAL	198	33	29	6	2	1	360	61	44
	GROSSE TETE	2	0	1	0	0	0	5	0	2
	MARINGOUIN	1	0	1	0	0	0	1	0	1
	PLAQUEMINE	77	11	9	1	0	0	118	19	14
	ROSEDALE	3	0	0	0	0	0	9	0	0
	WHITE CASTLE	11	3	2	0	0	0	28	8	6
PARISH TOTALS	292	47	42	7	2	1	521	88	67	
JACKSON	RURAL	66	10	10	1	0	1	101	11	15
	CHATHAM	3	1	1	0	0	0	4	1	2
	HODGE	3	0	0	0	0	0	4	0	0
	JONESBORO	5	2	2	0	0	0	8	4	4
	QUITMAN	1	0	1	0	0	0	2	0	2
	PARISH TOTALS	78	13	14	1	0	1	119	16	23
JEFFERSON	URBAN	4,420	631	285	30	12	10	6,868	960	489
	GRETNA	203	34	16	6	3	2	339	51	28
	HARAHAN	48	10	3	1	0	0	69	15	7
	KENNER	699	159	34	4	1	0	1,066	234	54
	WESTWEGO	112	23	5	0	0	0	178	38	7
	PARISH TOTALS	5,482	857	343	41	16	12	8,520	1,298	585
JEFFERSON DAVIS	RURAL	119	31	21	15	10	5	190	44	26
	ELTON	5	0	0	1	0	0	9	0	0
	FENTON	1	0	0	0	0	0	1	0	0
	JENNINGS	111	15	2	1	1	0	170	26	3
	LAKE ARTHUR	11	3	0	0	0	0	16	7	0
	WELSH	18	2	2	1	0	1	27	5	1
PARISH TOTALS	265	51	25	18	11	6	413	82	30	
LAFAYETTE	RURAL	472	88	57	16	12	2	728	118	83
	BROUSSARD	5	2	1	1	0	0	4	2	1
	CARENCRO	4	1	0	1	1	0	8	0	0
	DUSON	11	3	4	1	1	1	14	2	5
	LAFAYETTE	1,567	133	20	13	8	0	2,440	215	33
	SCOTT	60	11	13	2	2	2	102	19	18
YOUNGSVILLE	8	1	0	0	0	0	9	1	0	
2809	4	1	2	0	0	0	4	1	2	
2878	1	1	0	0	0	0	1	1	0	
2886	2	0	0	0	0	0	3	0	0	
PARISH TOTALS	2,134	241	97	34	24	5	3,313	359	142	

DATA AVAILABLE AS OF 03/11/94

ALC FATALITIES + SPD FATALITIES MAY BE GREATER THAN THE
 TOTAL FATALITIES SINCE A CRASH MAY BE ALC AND SPD INVOLVED

LOUISIANA HIGHWAY SAFETY COMMISSION
 FATAL AND INJURY ACCIDENT DATA
 =====> 1992 <=====

PARISH NAME	AREA	--ACCIDENTS--			--FATALITIES--			--INJURIES--			
		ALL	ALC	SPD	ALL	ALC	SPD	ALL	ALC	SPD	
LAFOURCHE	RURAL	753	138	80	20	12	4	1,201	224	143	
	GOLDEN MEADOW	1	0	0	0	0	0	1	0	0	
	LOCKPORT	9	0	0	0	0	0	12	0	0	
	THIBODAUX	135	13	22	0	0	0	227	18	40	
	2905	1	0	0	0	0	0	2	0	0	
	2909	1	0	0	0	0	0	1	0	0	
	2963	1	0	1	0	0	0	1	0	1	
2983	12	2	0	0	0	0	25	3	0		
PARISH TOTALS	913	153	103	20	12	4	1,470	245	184		
LA SALLE	RURAL	65	15	19	2	1	2	103	30	36	
	JENA	28	3	2	0	0	0	41	5	3	
	OLLA	2	1	1	0	0	0	2	1	1	
	PARISH TOTALS	95	19	22	2	1	2	146	36	40	
LINCOLN	RURAL	128	19	21	7	1	5	186	34	21	
	CHOUDRANT	2	0	1	1	0	1	7	0	6	
	DUBACH	1	0	0	0	0	0	1	0	0	
	GRAMBLING	4	1	0	0	0	0	5	2	0	
	RUSTON	195	16	23	0	0	0	302	23	37	
	SIMSBORO	1	0	0	0	0	0	2	0	0	
	VIENNA	4	1	0	0	0	0	12	2	0	
	PARISH TOTALS	335	37	45	8	1	6	515	61	64	
	LIVINGSTON	RURAL	395	78	44	16	8	3	649	143	69
		ALBANY	7	0	2	0	0	0	13	0	2
DENHAM SPRINGS		162	12	1	1	0	0	253	17	2	
LIVINGSTON		13	1	0	0	0	0	21	3	0	
WALKER		54	4	4	0	0	0	121	6	9	
PARISH TOTALS		631	95	51	17	8	3	1,057	169	82	
MADISON		RURAL	42	7	6	9	3	3	67	7	7
	DELTA	2	1	0	0	0	0	5	3	0	
	TALLULAH	40	3	1	0	0	0	74	4	4	
	3382	5	0	2	0	0	0	5	0	2	
	PARISH TOTALS	89	11	9	9	3	3	151	14	13	
MOREHOUSE	RURAL	108	17	24	5	1	1	185	26	53	
	BASTROP	180	14	21	1	0	0	348	31	46	
	BONITA	3	1	1	0	0	0	4	1	1	
	COLLINGTON	1	0	0	0	0	0	1	0	0	
	MER ROUGE	3	0	0	0	0	0	3	0	0	
	OAK RIDGE	3	0	0	0	0	0	4	0	0	
	3406	4	0	0	0	0	0	41	0	0	
PARISH TOTALS	302	32	46	6	1	1	586	58	100		

DATA AVAILABLE AS OF 03/11/94

ALC FATALITIES + SPD FATALITIES MAY BE GREATER THAN THE
 TOTAL FATALITIES SINCE A CRASH MAY BE ALC AND SPD INVOLVED

LOUISIANA HIGHWAY SAFETY COMMISSION
 FATAL AND INJURY ACCIDENT DATA
 =====> 1992 <=====

PARISH NAME	AREA	--ACCIDENTS--		--FATALITIES--		--INJURIES--	
		ALL	ALC	ALL	ALC	ALL	ALC
NATCHITOCHES	RURAL	143	30	13	9	220	44
	CAMPTI	1	0	0	0	1	0
	CLARENCE	3	1	0	0	4	1
	GOLDONNA	2	0	0	0	2	0
	NATCHEZ	3	0	0	0	4	0
	NATCHITOCHES	185	22	1	1	348	44
	PROVENCAL	2	0	0	0	2	0
	ROBELINE	4	1	0	0	6	3
	PARISH TOTALS	343	54	15	10	587	92
	ORLEANS	RURAL	2	0	0	0	3
NEW ORLEANS		5,775	189	69	18	9,863	349
3681		1	0	0	0	0	0
PARISH TOTALS		5,778	189	69	18	9,867	349
OUACHITA	RURAL	472	50	15	7	752	71
	MONROE	947	67	9	1	1,482	112
	STERLINGTON	4	1	0	0	5	1
	WEST MONROE	366	31	6	0	599	59
	3707	1	0	0	0	1	0
	3709	1	0	0	0	1	0
	PARISH TOTALS	1,791	149	30	8	2,840	243
	PLAQUEMINES	RURAL	197	31	11	4	333
PARISH TOTALS		197	31	11	4	333	41
POINTE COUPEE	RURAL	127	21	12	5	260	45
	LIVONIA	11	1	1	1	26	0
	MORGANZA	1	0	0	0	1	0
	NEW ROADS	54	4	0	0	94	10
	PARISH TOTALS	193	26	13	6	381	55
RAPIDES	RURAL	385	64	16	7	604	101
	ALEXANDRIA	1,028	67	5	0	1,715	143
	BALL	3	0	0	0	5	0
	BOYCE	1	0	0	0	3	0
	CHENEYVILLE	2	0	0	0	5	0
	FOREST HILL	5	0	1	0	10	0
WOODWORTH	LECOMPTÉ	10	1	0	0	16	1
	MC NARY	2	0	0	0	3	0
	PINEVILLE	196	18	1	0	313	30
	WOODWORTH	3	1	1	1	10	5
	PARISH TOTALS	1,635	151	24	8	2,684	280

DATA AVAILABLE AS OF 03/11/94

ALC FATALITIES * SPD FATALITIES MAY BE GREATER THAN THE
 TOTAL FATALITIES SINCE A CRASH MAY BE ALC AND SPD INVOLVED

LOUISIANA HIGHWAY SAFETY COMMISSION
 FATAL AND INJURY ACCIDENT DATA
 =====> 1992 <=====

PARISH NAME	AREA	--ACCIDENTS--			--FATALITIES--			--INJURIES--		
		ALL	ALC	SPD	ALL	ALC	SPD	ALL	ALC	SPD
RED RIVER	RURAL	45	6	13	7	2	3	64	7	18
	COUSHATTA	1	0	1	0	0	0	1	0	1
	PARISH TOTALS	46	6	14	7	2	3	65	7	19
RICHLAND	RURAL	97	23	20	5	2	1	151	33	33
	DELHI	17	1	6	0	0	0	29	1	13
	PARISH TOTALS	117	25	27	5	2	1	185	35	47
SABINE	RURAL	97	16	30	2	1	0	139	22	40
	CONVERSE	1	0	0	1	0	0	1	0	0
	PARISH TOTALS	98	16	30	3	1	0	140	22	40
ST BERNARD	RURAL	566	60	49	16	11	5	954	95	84
	PARISH TOTALS	566	60	49	16	11	5	954	95	84
	PARISH TOTALS	441	61	99	16	2	10	697	96	150
ST CHARLES	RURAL	441	61	99	16	2	10	697	96	150
	PARISH TOTALS	441	61	99	16	2	10	697	96	150
	PARISH TOTALS	48	14	12	7	6	3	81	15	17
ST HELENA	RURAL	48	14	12	7	6	3	81	15	17
	GREENSBURG	1	0	0	0	0	0	6	0	0
	PARISH TOTALS	49	14	12	7	6	3	87	15	17
ST JAMES	RURAL	168	30	29	2	1	1	288	52	49
	GRAMERCY	17	0	2	0	0	0	23	0	2
	PARISH TOTALS	189	30	31	2	1	1	318	52	51
ST JOHN	RURAL	369	53	66	13	2	6	615	99	116
	PARISH TOTALS	369	53	66	13	2	6	615	99	116
	PARISH TOTALS	306	61	25	10	4	0	534	108	43
ST LANDRY	RURAL	306	61	25	10	4	0	534	108	43
	CANKTON	2	0	0	0	0	0	3	0	0
	PARISH TOTALS	308	61	25	10	4	0	537	108	43
ST LANDRY	RURAL	306	61	25	10	4	0	534	108	43
	GRAND COTEAU	4	0	0	0	0	0	5	0	0
	PARISH TOTALS	310	61	25	10	4	0	539	108	43
ST LANDRY	RURAL	306	61	25	10	4	0	534	108	43
	KROTZ SPRINGS	4	0	1	0	0	0	5	0	1
	PARISH TOTALS	310	61	26	10	4	0	539	108	44
ST LANDRY	RURAL	306	61	25	10	4	0	534	108	43
	MELVILLE	2	0	0	0	0	0	5	0	0
	PARISH TOTALS	308	61	25	10	4	0	539	108	43
ST LANDRY	RURAL	306	61	25	10	4	0	534	108	43
	PELOUSAS	247	26	12	4	4	3	416	39	17
	PARISH TOTALS	553	87	37	14	8	3	950	147	60
ST LANDRY	RURAL	306	61	25	10	4	0	534	108	43
	PALMETTO	1	0	0	0	0	0	3	0	0
	PARISH TOTALS	307	61	25	10	4	0	537	108	43
ST LANDRY	RURAL	306	61	25	10	4	0	534	108	43
	PORT BARRE	1	1	0	0	0	0	1	1	0
	PARISH TOTALS	307	62	25	10	4	0	535	109	43

DATA AVAILABLE AS OF 03/11/94

ALC FATALITIES + SPD FATALITIES MAY BE GREATER THAN THE
 TOTAL FATALITIES SINCE A CRASH MAY BE ALC AND SPD INVOLVED

LOUISIANA HIGHWAY SAFETY COMMISSION
 FATAL AND INJURY ACCIDENT DATA
 =====> 1992 <=====

PARISH NAME	AREA	--ACCIDENTS--			--FATALITIES--			--INJURIES--			
		ALL	ALC	SPD	ALL	ALC	SPD	ALL	ALC	SPD	
ST LANDRY	SUNSET	9	1	0	0	0	0	10	1	0	
	WASHINGTON	6	0	1	0	0	0	6	0	1	
	ARNAUDVILLE	1	1	0	0	0	0	1	1	0	
	EUNICE	192	17	6	1	0	1	306	33	8	
	PARISH TOTALS	780	107	46	15	8	4	1,301	183	71	
ST MARTIN	RURAL	330	65	37	10	7	1	501	98	60	
	BREAUX BRIDGE	72	7	2	0	0	0	113	11	2	
	HENDERSON	8	1	1	0	0	0	20	2	3	
	PARKS	2	0	0	0	0	0	4	0	0	
	ST MARTINVILLE	86	9	4	0	0	0	128	16	8	
	5013	3	0	0	0	0	0	4	0	0	
	5092	8	1	0	0	0	0	17	3	0	
PARISH TOTALS	509	83	44	10	7	1	787	130	73		
ST MARY	RURAL	186	47	45	8	5	4	326	73	75	
	BERWICK	34	6	6	1	1	1	48	9	5	
	FRANKLIN	85	10	10	2	0	1	133	16	19	
	MORGAN CITY	128	8	6	1	0	0	209	12	8	
	PATTERSON	20	5	3	1	1	1	36	5	2	
	PARISH TOTALS	453	76	70	13	7	7	752	115	109	
	ST TAMMANY	RURAL	703	129	154	23	13	12	1,135	205	237
ABITA SPRINGS		8	0	2	0	0	0	12	0	2	
COVINGTON		101	14	18	2	1	1	145	23	30	
FOLSOM		5	0	1	0	0	0	5	0	1	
MADISONVILLE		7	0	1	0	0	0	12	0	1	
MANDEVILLE		190	18	19	1	1	0	301	23	30	
PEARL RIVER		30	6	10	1	1	0	46	10	15	
SLIDELL		434	47	34	3	1	0	698	75	53	
SUN		1	0	0	0	0	0	2	0	0	
5220		1	0	0	0	0	0	1	0	0	
PARISH TOTALS		1,480	214	239	30	17	13	2,357	336	369	
TANGIPAHOA		RURAL	495	62	72	17	5	5	865	104	121
		AMITE	39	3	2	2	1	0	69	6	7
	HAMMOND	494	37	41	8	6	1	894	77	88	
	INDEPENDENCE	3	1	0	1	1	0	4	0	0	
	KENTWOOD	26	2	2	2	2	2	53	5	6	
	PONCHATOULA	13	3	2	0	0	0	24	3	2	
	TANGIPAHOA	1	0	0	3	0	0	2	0	0	
	TICKEFAW	1	0	0	0	0	0	4	0	0	
	PARISH TOTALS	1,072	108	119	33	15	8	1,915	195	224	

ALC FATALITIES + SPD FATALITIES MAY BE GREATER THAN THE
 TOTAL FATALITIES SINCE A CRASH MAY BE ALC AND SPD INVOLVED

LOUISIANA HIGHWAY SAFETY COMMISSION
 FATAL AND INJURY ACCIDENT DATA
 =====> 1992 <=====

PARISH NAME	AREA	--ACCIDENTS--			--FATALITIES--			--INJURIES--			
		ALL	ALC	SPD	ALL	ALC	SPD	ALL	ALC	SPD	
TENSAS	RURAL	19	2	7	1	0	0	27	3	9	
	NEWELLTON	1	0	0	0	0	0	2	0	0	
	ST JOSEPH	5	0	1	0	0	0	10	0	3	
	WATERPROFF	2	0	0	0	0	0	6	0	0	
	PARISH TOTALS	27	2	8	1	0	0	45	3	12	
TERREBONNE	RURAL	938	155	83	31	18	5	1,680	282	130	
	HOUMA	435	47	18	2	0	1	716	82	24	
	PARISH TOTALS	1,373	202	101	33	18	6	2,396	364	154	
UNION	RURAL	103	19	24	3	1	1	166	24	34	
	BERNICE	15	0	4	0	0	0	23	0	5	
	FARMERVILLE	42	3	6	0	0	0	56	3	7	
	MARION	3	0	1	0	0	0	5	0	1	
	SPEARSVILLE	1	0	1	0	0	0	3	0	3	
	DOWNSVILLE	3	0	2	0	0	0	6	0	5	
	PARISH TOTALS	167	22	38	3	1	1	259	27	55	
VERMILION	RURAL	218	44	33	9	5	0	324	60	52	
	ABBEVILLE	181	16	24	5	2	1	358	35	41	
	ERATH	31	4	2	0	0	0	64	13	3	
	GUEYDAN	9	0	0	1	0	0	10	0	0	
	KAPLAN	55	6	6	0	0	0	78	9	12	
	MAURICE	7	1	1	0	0	0	10	1	2	
	DELCAMBRE	3	1	3	0	0	0	3	1	3	
	PARISH TOTALS	504	72	69	15	7	1	847	119	113	
	VERNON	RURAL	267	39	83	7	2	4	437	71	142
		ANACOCO	1	0	1	0	0	0	1	0	1
LEESVILLE		105	10	10	0	0	0	168	15	12	
NEWLLANO		1	0	0	0	0	0	1	0	0	
ROSEFINE		10	1	3	0	0	0	21	1	4	
SIMPSON		5	0	3	1	0	1	4	0	2	
PARISH TOTALS	389	50	100	8	2	5	632	87	161		
WASHINGTON	RURAL	134	28	36	17	5	7	205	37	52	
	ANGIE	4	0	0	0	0	0	9	0	0	
	BOGALUSA	196	20	27	5	3	3	320	31	47	
	FRANKLINTON	37	2	8	0	0	0	57	2	13	
	VARNADO	4	0	0	0	0	0	5	0	0	
PARISH TOTALS	375	50	71	22	8	10	596	70	112		

ALC FATALITIES + SPD FATALITIES MAY BE GREATER THAN THE
 TOTAL FATALITIES SINCE A CRASH MAY BE ALC AND SPD INVOLVED

LOUISIANA HIGHWAY SAFETY COMMISSION
 FATAL AND INJURY ACCIDENT DATA
 <-----> 1992 <----->

PARISH NAME	AREA	--ACCIDENTS--			--FATALITIES--			--INJURIES--		
		ALL	ALC	SPD	ALL	ALC	SPD	ALL	ALC	SPD
WEBSTER	RURAL	193	46	59	9	4	9	306	72	98
	DOYLINE	4	0	0	0	0	0	4	0	0
	MINDEN	116	8	2	0	0	0	191	16	4
	SARPETA	1	0	0	0	0	0	4	0	0
	SHONGALOO	3	0	0	0	0	0	3	0	0
SPRINGHILL	70	14	9	3	0	1	99	18	10	
PARISH TOTALS		387	68	70	12	4	10	607	106	112
WEST BATON ROUGE	RURAL	237	27	10	8	4	0	409	41	17
	BRUSLY	3	1	1	0	0	0	6	3	3
	PORT ALLEN	46	6	2	1	0	0	67	12	3
	PARISH TOTALS	286	34	13	9	4	0	482	56	23
WEST CARROLL	RURAL	30	5	5	2	0	1	47	10	9
	EPPS	2	0	0	0	0	0	5	0	0
	OAK GROVE	21	1	1	0	0	0	39	3	3
	PIONEER	2	1	1	0	0	0	3	2	2
PARISH TOTALS	55	7	7	2	0	1	94	15	14	
WEST FELICIANA	RURAL	36	6	5	3	2	0	62	14	7
	ST FRANCISVILLE	19	3	1	0	0	0	41	8	3
	PARISH TOTALS	55	9	6	3	2	0	103	22	10
	WINN	69	16	18	1	1	1	108	27	21
WINN	CALVIN	3	1	0	0	0	0	7	3	0
	DODSON	2	0	2	0	0	0	2	0	2
	WINNFIELD	47	0	0	0	0	0	74	0	0
	PARISH TOTALS	121	17	20	1	1	1	191	30	23
* ALL PARISHES *		46,640	5,413	4,301	892	371	257	76,676	8,915	7,103

DATA AVAILABLE AS OF 03/11/94

ALC FATALITIES + SPD FATALITIES MAY BE GREATER THAN THE
 TOTAL FATALITIES SINCE A CRASH MAY BE ALC AND SPD INVOLVED

1992

YOUTH TRAFFIC

CRASH DATA

1992 LOUISIANA FACTS ON YOUTH CRASHES, FATALITIES AND INJURIES

129 drivers below the age of 25 were killed in traffic crashes during 1992. This number is down 8% from the 140 drivers killed in 1991.

- 55 (or 43%) were either partially or completely ejected from the vehicle.
- 70 (or 54%) were killed in single-vehicle crashes.
- 98 (or 76%) of the young drivers were males.

101 occupants ages 1– 24 were killed in traffic crashes during 1992.

- 52% of the occupant fatalities were in alcohol-involved crashes.
- 55% of the occupant fatalities occurred while riding in a vehicle with a driver from the ages of 15 to 24.
- 63% of the occupant fatalities among youth (0–24) were within the 15–24 year old age group.

46 pedestrians below the age of 24 were killed in traffic crashes during 1992, and 30% of those fatalities were alcohol-involved.

1992 LOUISIANA FACTS ON YOUTH CRASHES, FATALITIES, AND INJURIES

During 1992 in Louisiana, 96 young people from the ages of 15 to 19 lost their lives in traffic crashes:

- 53 of them were driving,
- 33 of them were riding in a vehicle, and
- 10 of them were walking.

Of the seven 15 and 16 year old drivers who were killed, all but one died in a crash that occurred during daytime hours. At age 17, there was a sharp increase in the number of young drivers killed during late evening and early morning hours.

Young drivers 15–24 years of age are over-represented in traffic crashes. Drivers in that age group were involved in 26% of all fatal and injury crashes. Even more, drivers in that age group were involved in 41% of all ALCOHOL- INVOLVED fatal and injury crashes.

1988-1992 DRIVER FATALITIES DRIVERS 15-20 YEARS OF AGE

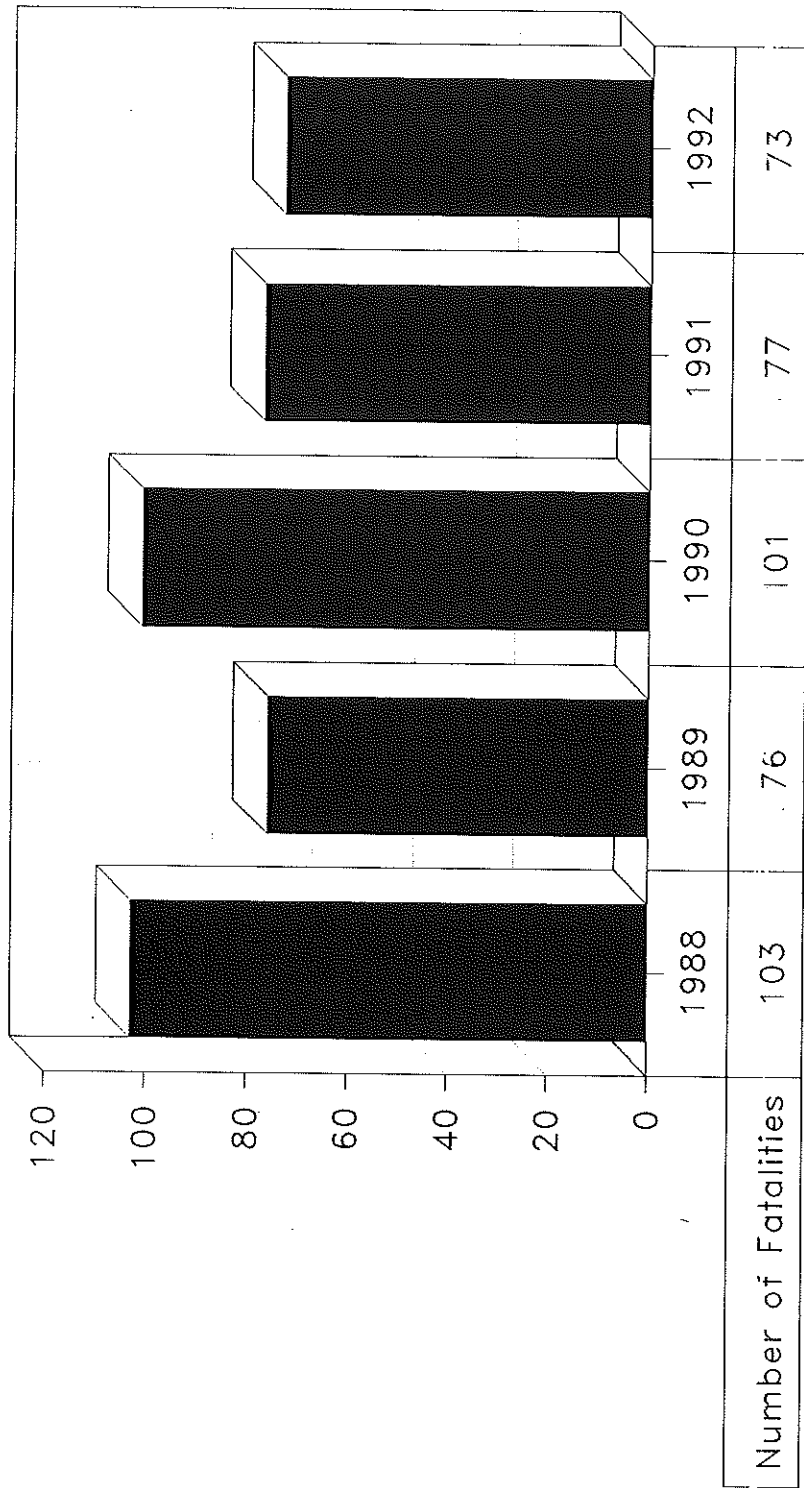

Louisiana Data

LOUISIANA FATALITIES

Drivers and Occupants 15-20 Years of Age

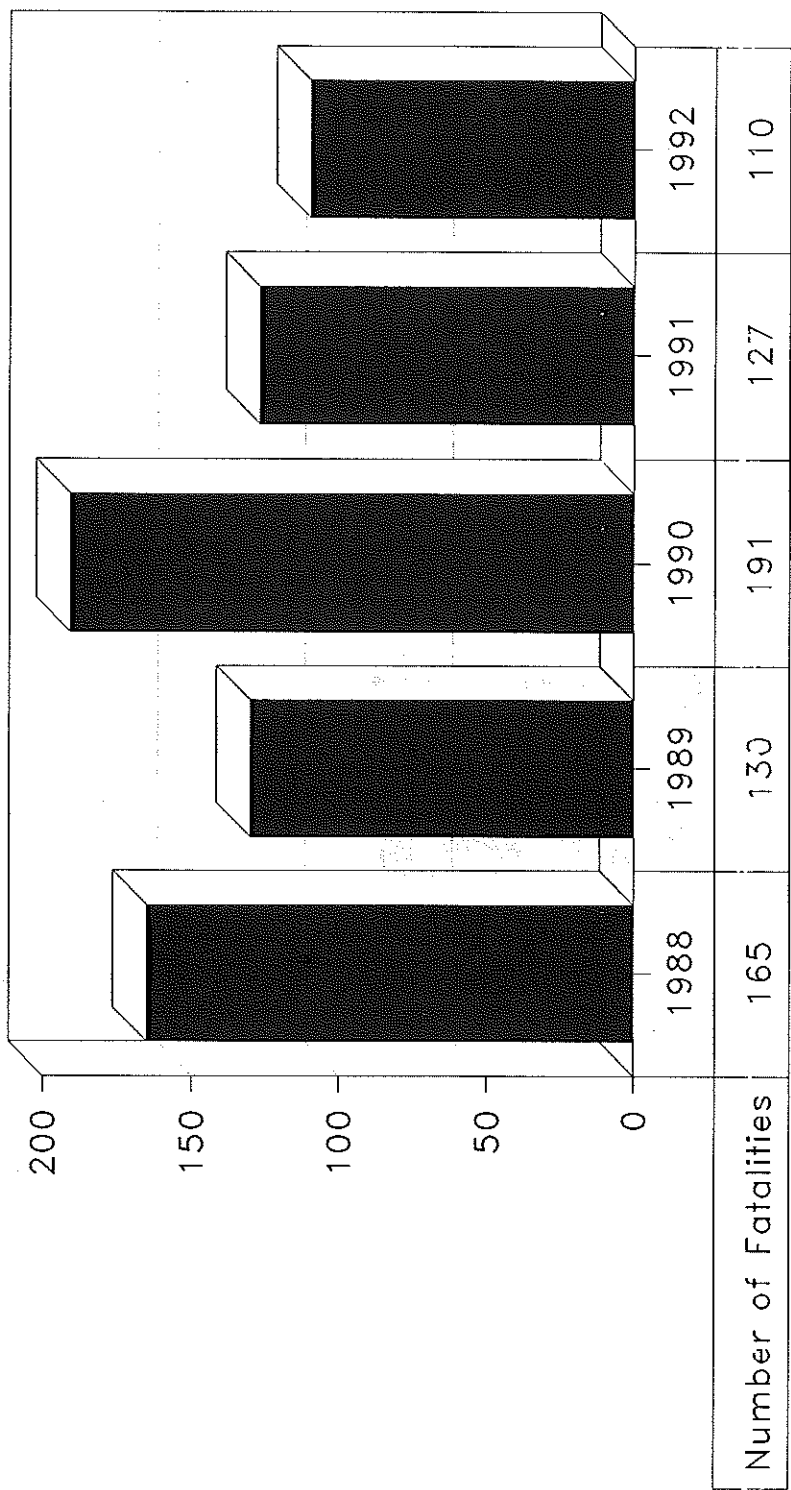

■ Number of Fatalities

Occupant fatalities in all crashes.

FATAL & INJURY CRASHES INVOLVING DRIVERS 15-20 YEARS OF AGE

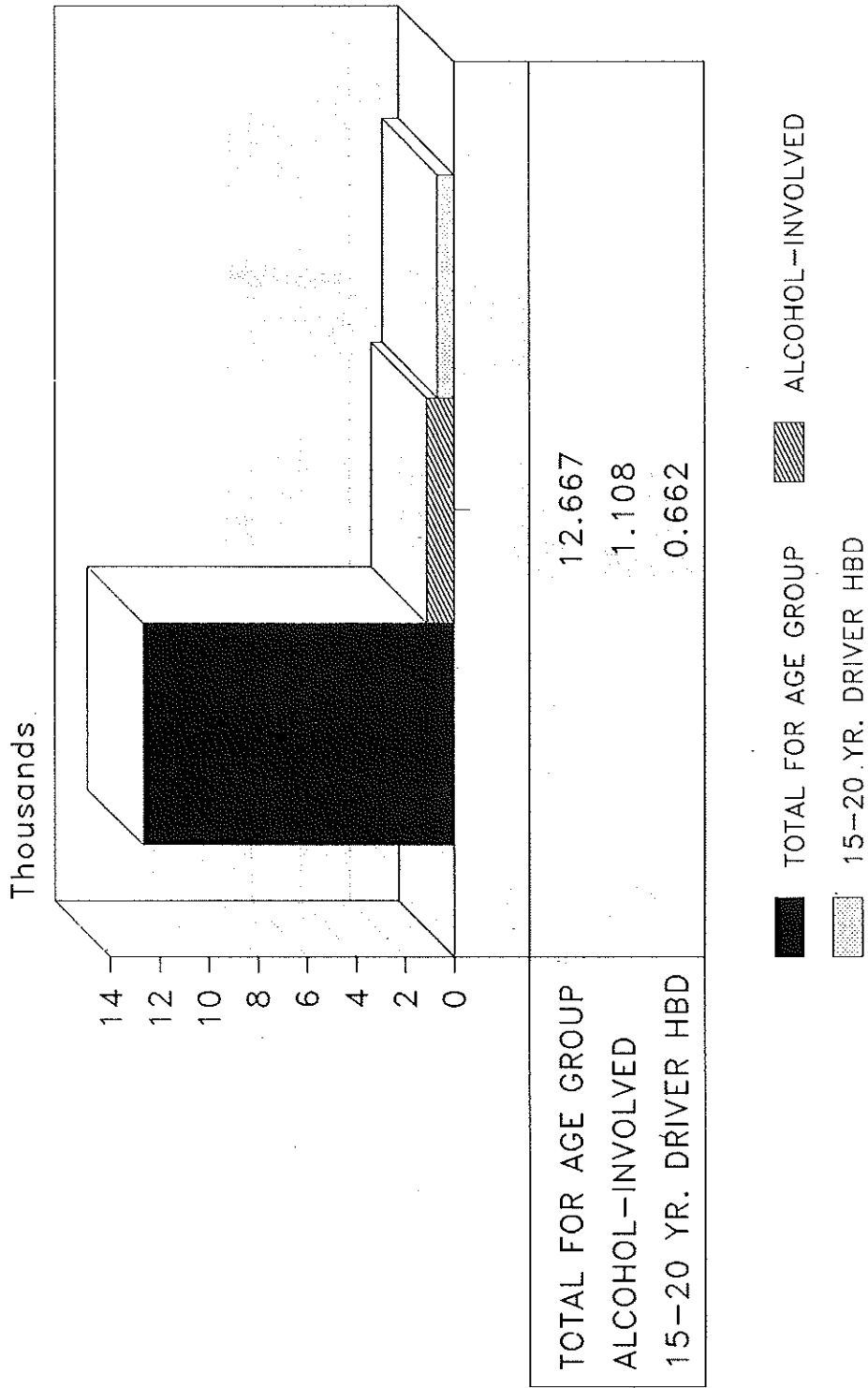

1992 LOUISIANA DATA

Fatal and Injury Crashes Involving Drivers 15-20 Years of Age

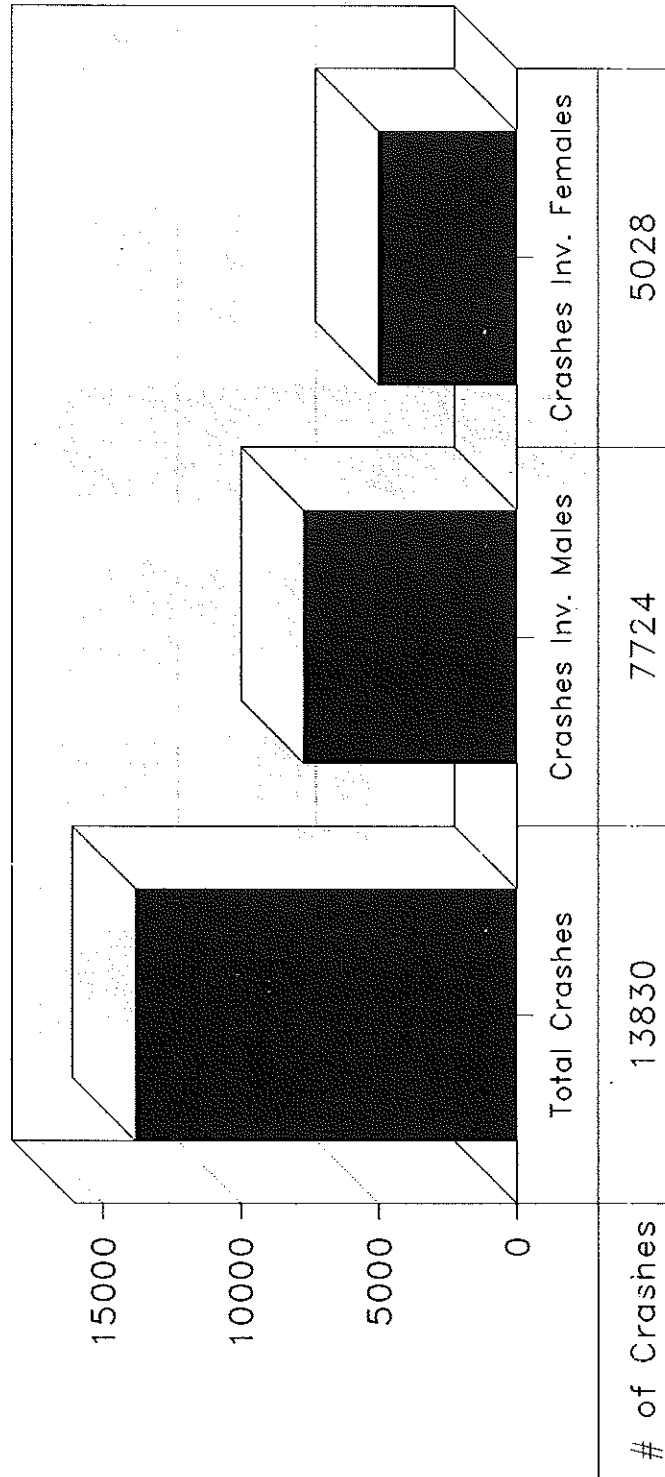

■ # of Crashes

1992 Louisiana Data

Fatalities Involving Drivers 15-24 Years By Hour of Crash Occurrence

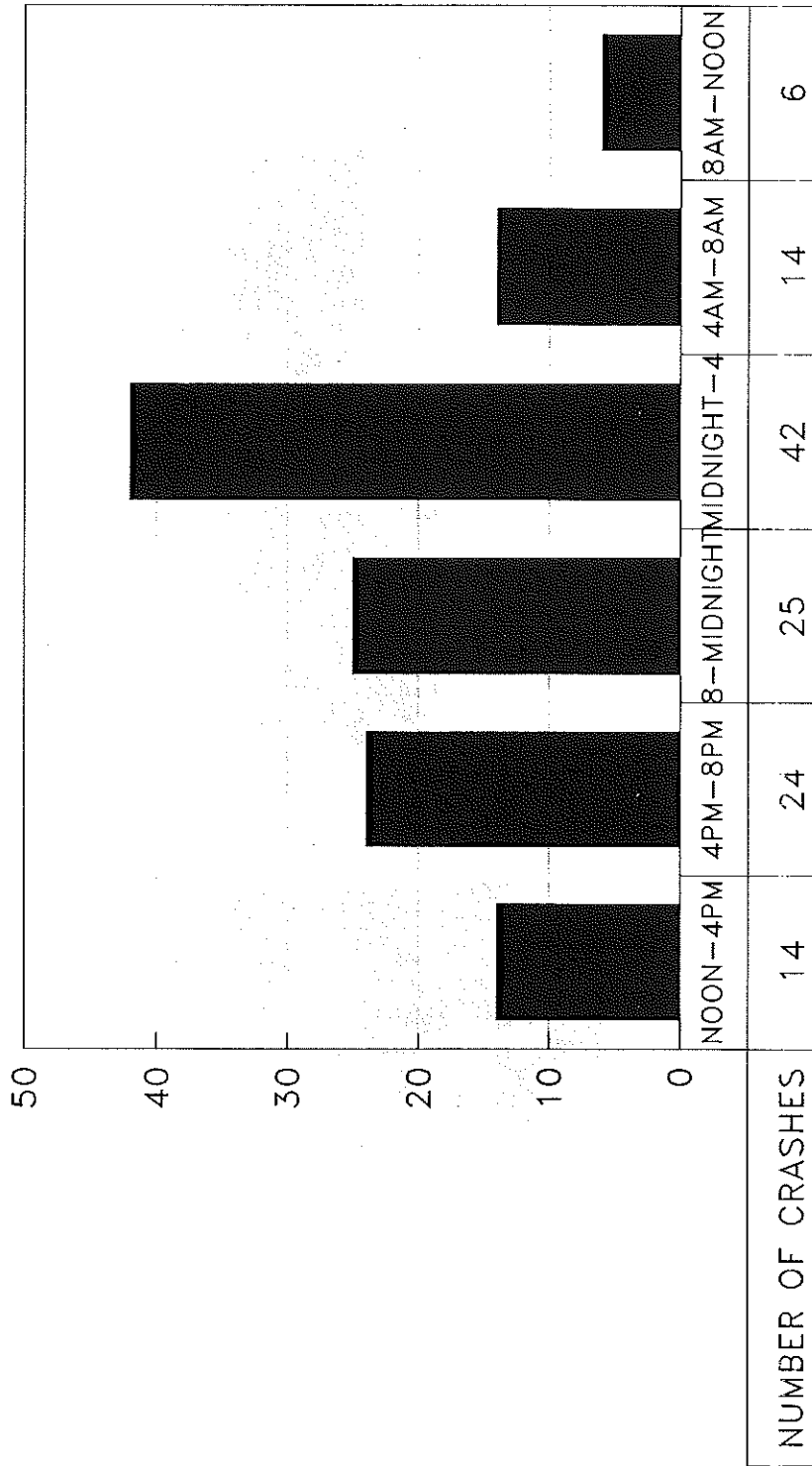

■ NUMBER OF CRASHES

15-24 YEAR OLD DRIVER FATALITIES
BY MONTH

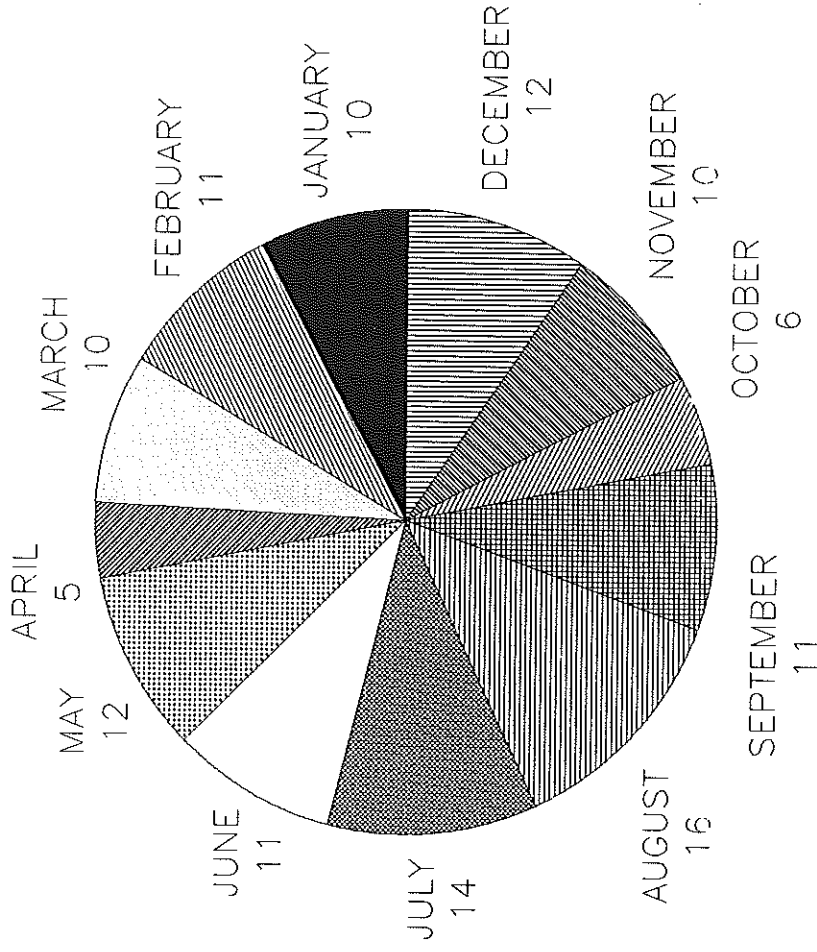

LOUISIANA DATA

15-24 YEAR OLD DRIVER FATALITIES BY DAY OF WEEK

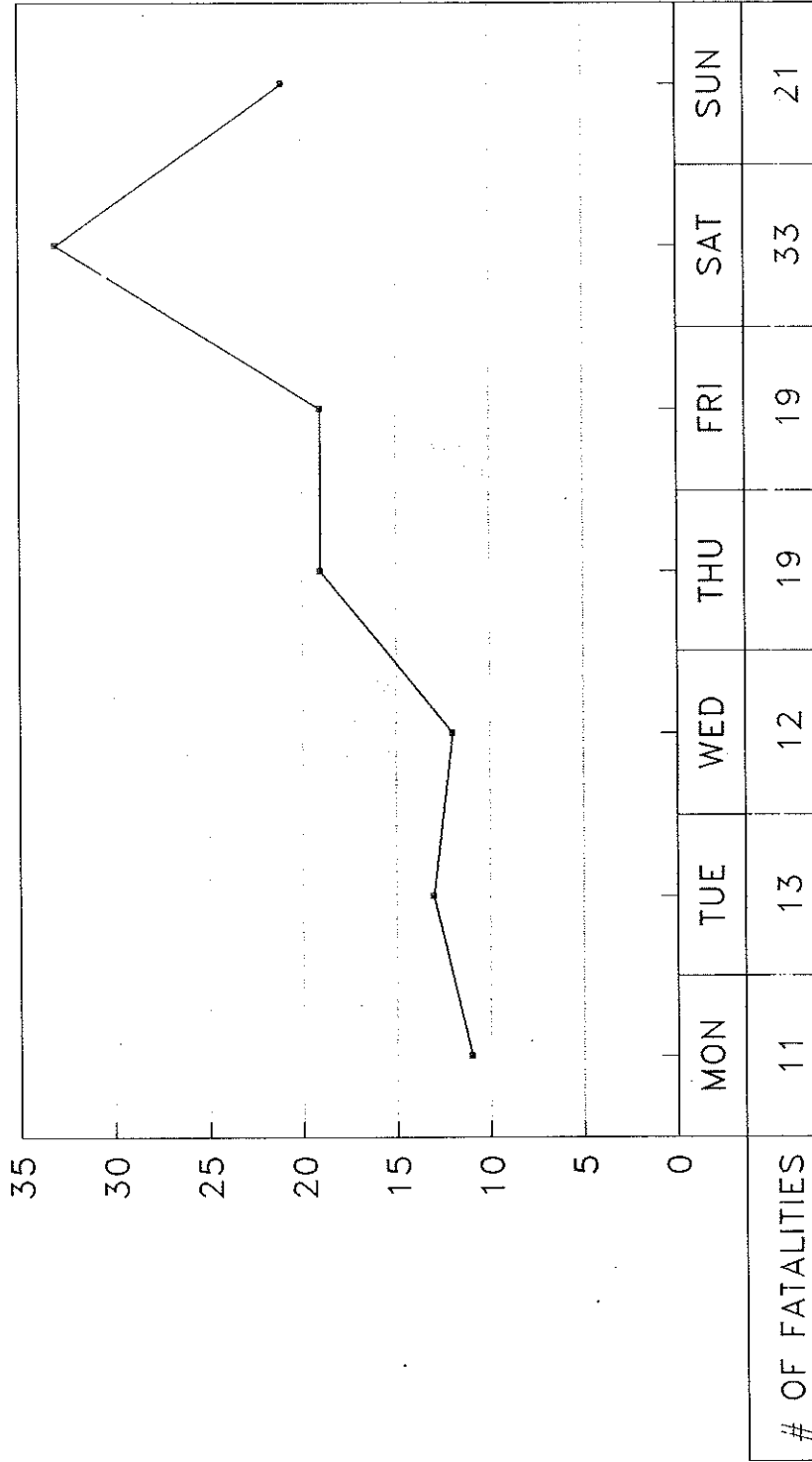

—●— # OF FATALITIES

1992 LOUISIANA DATA

15-24 YR. OLD DRIVER FATALITIES
CONDITION OF 15-24 YR. OLD DRIVER

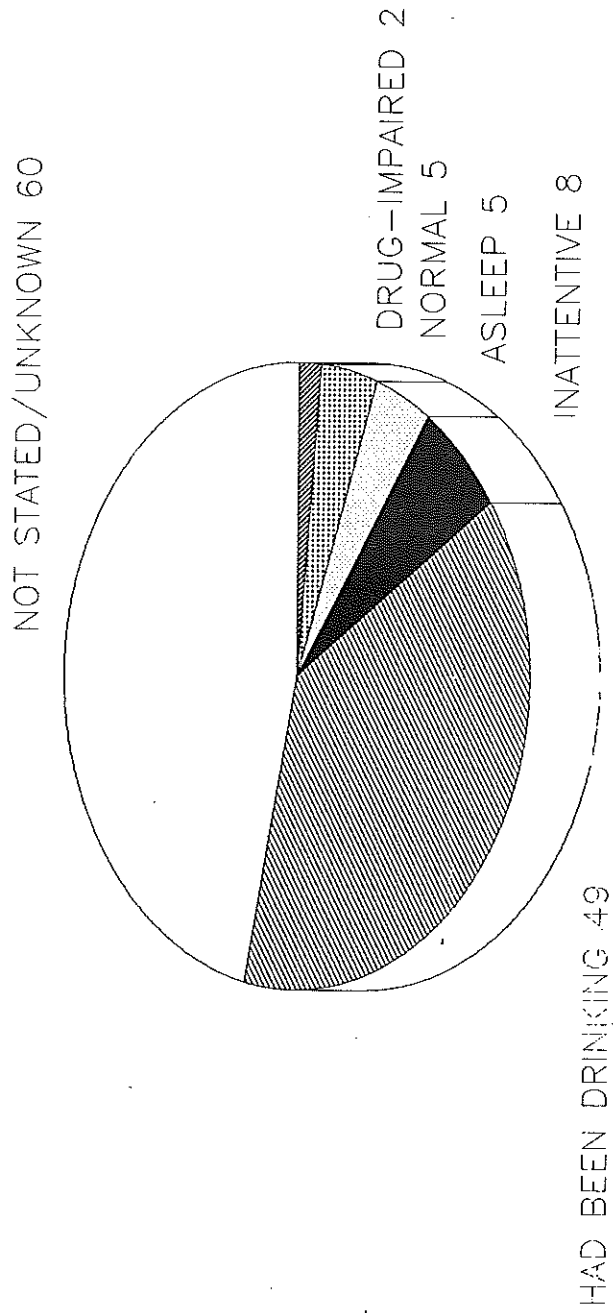

I. OCCUPANT PROTECTION ENFORCEMENT INFORMATION

Laws	Age/Size	Front Seat	Rear Seat	No Rear Seat
RS 32:295	Birth to 20 lbs (approx. 9-12 months)	infant/convertible seat rear facing ¹	infant/convertible seat rear facing	infant/convertible seat rear facing ²
Same	20 lbs through 2nd yr	convertible seat forward facing	convertible seat forward facing	convertible seat forward facing
Same	3 and 4 year olds	convertible seat or booster seat	convertible seat, booster seat or seat belt	convertible seat or booster seat
RS 32:295.1	persons 5 years and over	seat belt	seat belt not required by law	

Notes:

- When a vehicle with a passenger side airbag is used to transport an infant (under 20 lbs.) in a rear facing child safety seat, the infant must ride in a rear seating position in order to avoid injury due to the impact of the airbag on the rear facing child safety seat.
- In vehicles with passenger side airbags where there is no rear seat, infants in rear facing child safety seats should not be transported in the passenger seat due to the risk of injury from the impact of the airbag on the rear facing child safety seat.
- Generally, children in child safety seats are safest when transported in a useable center position of a rear seat.
- Child safety seats must meet Federal Standard 213 and be properly installed.
- Seat belt violations are to be issued to the driver unless violator is a front seat passenger 14 years of age or older.
- Child restraint violations will be issued to the driver.

R.S. 32:295 CHILD SAFETY SEAT LAW -- EXEMPTIONS:

- * bicycles
- * motor-driven cycles
- * trucks over 2000 lbs. carrying capacity
- * commercial trucks or vans
- * emergency vehicles (including vehicles used in emergency)
- * school or church buses
- * farm tractors
- * recreational vehicles with capacity of 10 or more
- * children physically unable to be restrained
- * no. of children exceed no. of seat belts,
unrestrained children to be placed in rear

R.S. 32:295.1 SEAT BELT LAW -- EXEMPTIONS:

- * motor vehicles manufactured prior to January 1, 1981
- * farm vehicles being operated within 5 miles of principle use
- * rural letter carriers of the U.S.P.S.
- * pickups over 6000 lbs. gross weight

II. OPEN PICKUP TRUCKS - Children under 6 years of age may not ride in the open bed of a pickup truck or utility trailer unless in an emergency situation and accompanied by an adult or in an authorized parade. (R.S. 32:284)



DRINKING AND DRIVING PENALTIES

DWI: The operation of any motor vehicle, aircraft, vessel or other means of conveyance by the operator when they:
 1) are under the influence of alcoholic beverages; or 2) have a blood alcohol concentration of .10% or greater; or
 3) are under the influence of narcotic drugs, central nervous system stimulants, hallucinogenic drugs or barbiturates.

UPON ARREST IMPLIED CONSENT LAW R.S. 32: 661-669 (Conviction is not Required)		UPON CONVICTION DRIVING WHILE INTOXICATED LAW R.S. 14:98 (DWI 1 & 2 are Misdemeanors ; DWI 3 & 4 are Felonies)								
DWI	LICENSE SUSPENSION* Submit to Test	Refuse Test	DWI	**	FINE	IMPRISONMENT	COMMUNITY SERVICE PROGRAM	SUBSTANCE ABUSE PROGRAM	DRIVER IMPROVEMENT PROGRAM	LICENSE SUSPENSION R.S. 32:414-415.1
1	90 days (60 day hardship provision, if eligible)	180 days (90 day hardship provision, if eligible)	1	(a)	\$125-500 + court costs	10 days to 6 months				90 days (hardship provision)
				(b)	same	2 days (48 hrs.)		X	X	same
				(c)	same		4, 8-hr. days	X	X	same
2	365 days (no hardship provision)	545 days (no hardship provision)	2	(a)	\$300-1000 + court costs	30 days to 6 months				12 months (no hardship provision)
				(b)	same	15 days		X	X	same
				(c)	same		30, 8-hr. days	X	X	same
3	365 days (no hardship provision)	545 days (no hardship provision)	3	(a)	up to \$2000 + court costs	1-5 years with or without hard labor				24 months (no hardship provision)
				(b)	same	1-5 years (6 months mandatory)		X	X	same
4	365 days (no hardship provision)	545 days (no hardship provision)	4	(a)	-0-	10-30 years hard labor				24 months (no hardship provision)

*Begins 30 days after arrest. ** (a), (b), (c) = possible sentences and probations for each DWI conviction.

(NOTE: SEE STATUTE FOR EXCEPTIONS)

Habitual Offender: Three year license suspension for 10 or more moving violations in a 3 year period - R.S. 32:1472.

Vehicular Homicide: Fine \$2000-15,000, prison no less than 2 years no more than 15 years - R.S. 14:32.1.

Vehicular Negligent Injury: Fine up to \$1000 and/or prison up to 6 months - R.S. 14:39.1.

Persons Under 21: It is illegal for persons under 21 years of age to buy, consume or have an alcoholic beverage in their possession - R.S. 14:91.5.

